

**PLAN SHOWING THE PROPOSED CONSTRUCTION OF R.C.C ROOF RESIDENTIAL GROUND FLOOR ,FIRST FLOOR AND SECOND FLOOR BUILDING IN SURVEY NO: 224/8B, PATTA NO: 574, AT PUDUPAKKAM VILLAGE & PANCHAYAT , VANDALUR TALUK & PANCHAYAT UNION,CHENGALPATTU DISTRICT.**

OWNER : Mr. SUKHALAL B

PLOT APPROVED No:e/f/vz ;2833/2024/M1  
ehs;28.08.2024

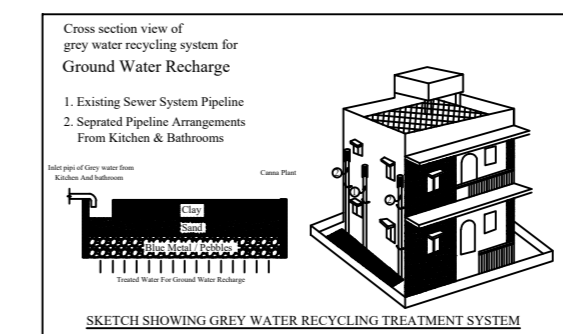
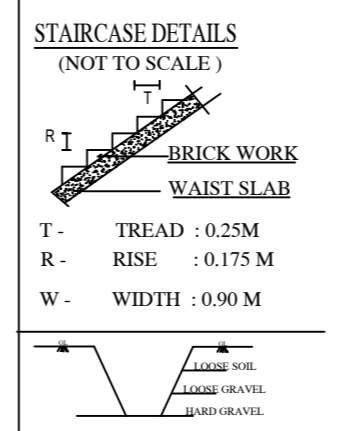
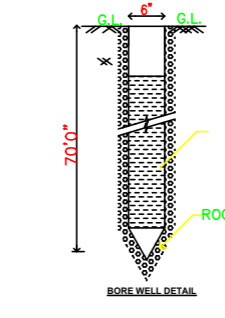
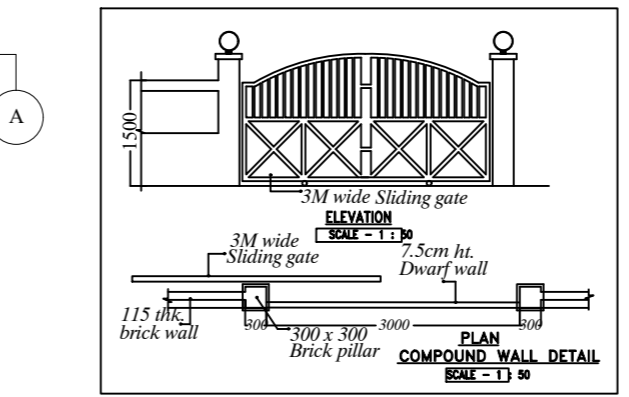
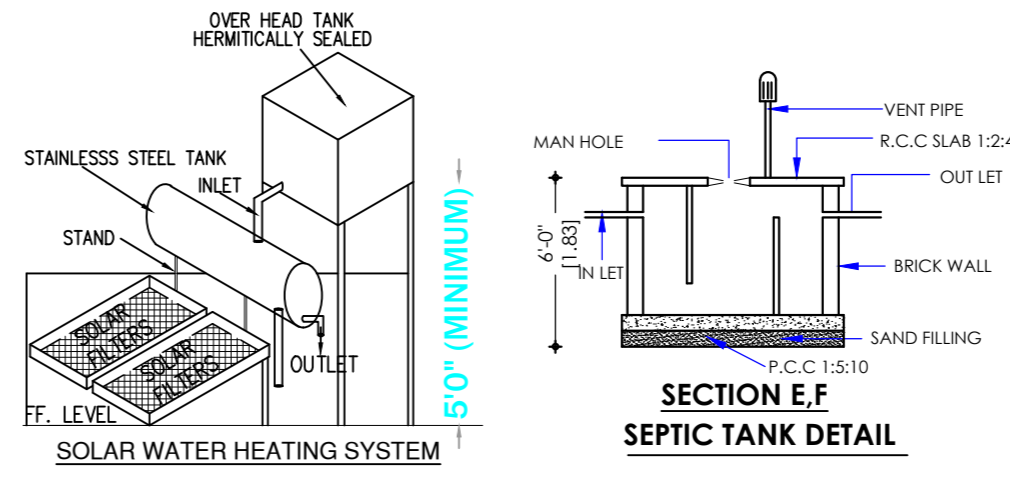
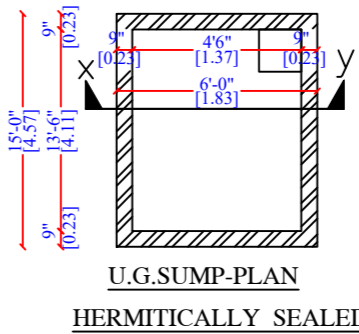
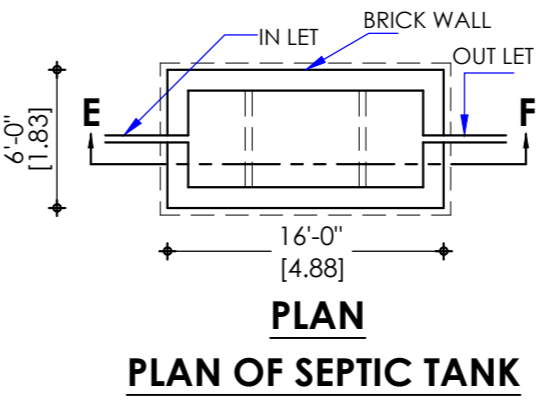
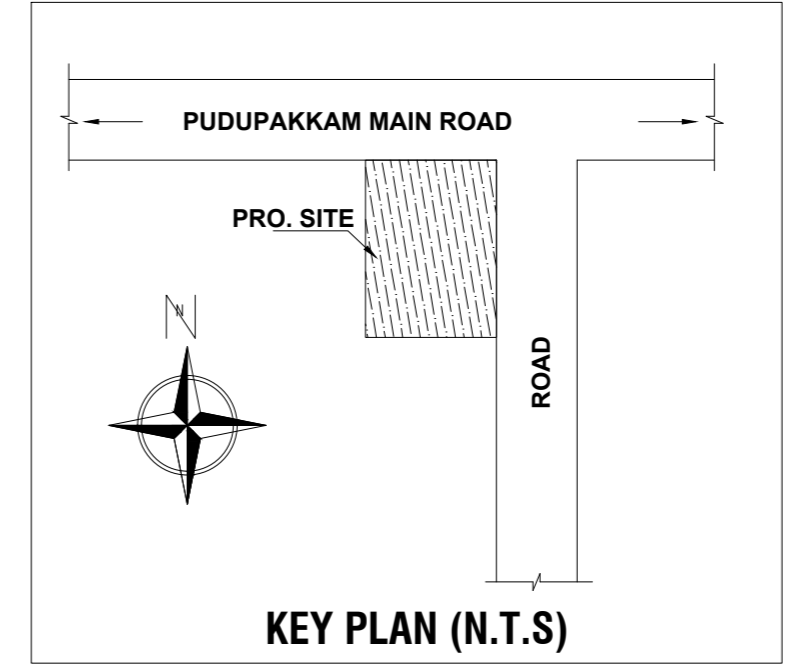
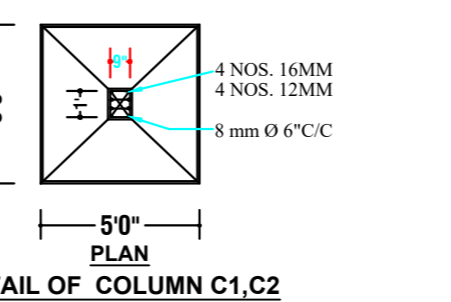
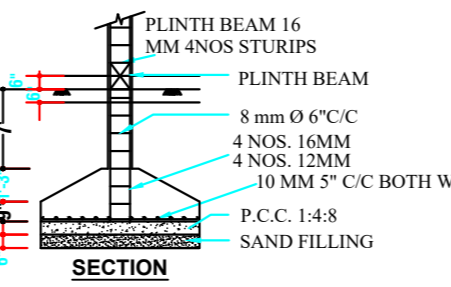
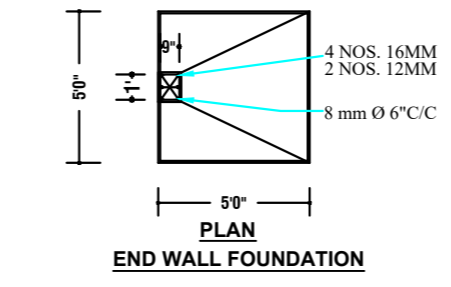
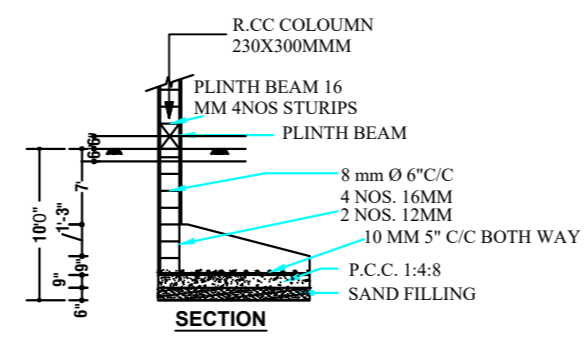
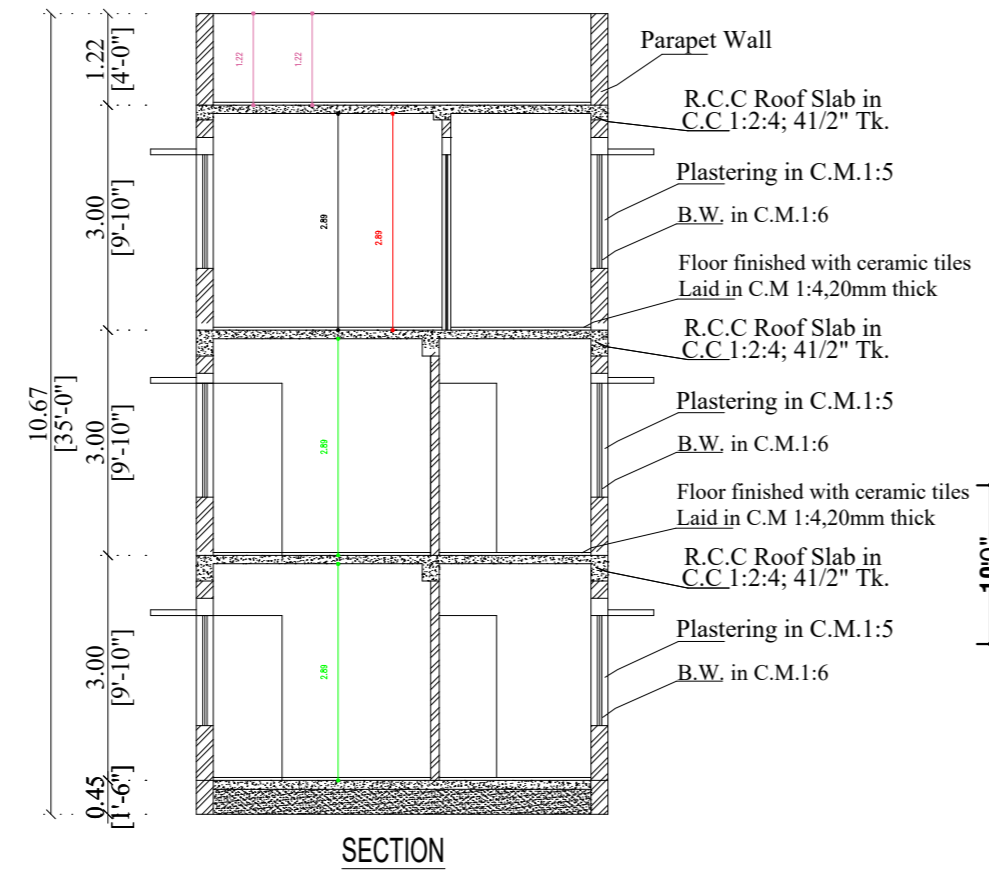
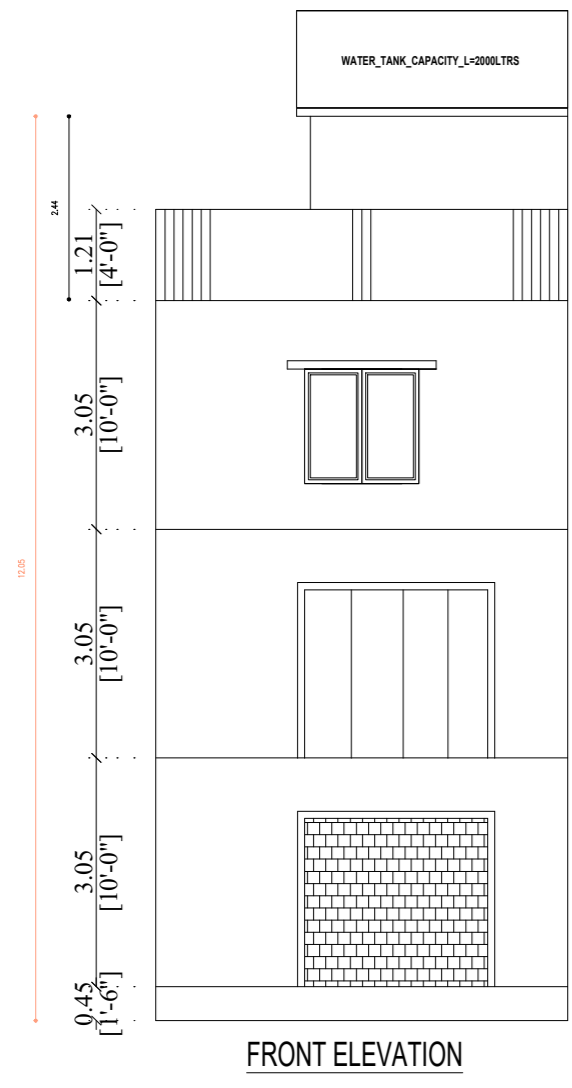

SPECIFICATION		COLOUR INDEX	
• FOUNDATION IN R.C.C 1:2:4, MIX WITH NECESSARY REINFORCEMENTS	• OVER P.C.C SAND FILLING BRICK IN CM 1:5, MIX USING STOCK BRICK	PROPOSED	<input type="checkbox"/>
• ALL RCC WORKS ARE 1:2:4, MIX WITH NECESSARY REINFORCEMENTS	• FLOORING CONCRETE 1:4:8, MIX, FINISHED CERAMIC TILES, JOINTRY ITEMS	BOUNDARY	<input type="checkbox"/>
• TEAK WOOD	• FINISHED PLASTERING IN CM 1:5, 12MM THICK & WHITE WASHING ONE	EXG. ROAD	<input type="checkbox"/>
• OVER TWO COAT OF CEMENT PAINT.			

SCHEDULE OF JOINERY		
MD	MAIN DOOR	3'6" X 7'0"
D	DOOR	3'0" X 7'0"
D1	DOOR	2'6" X 7'0"
W	WINDOW	6'0" X 4'0"
W1	WINDOW	4'0" X 4'0"
W2	WINDOW	3'0" X 4'0"
V	VENTILATOR	2'0" X 2'0"

AREA DETAILS			
S.NO.		SQ.M	SQ.FT
1	AS PER SITE	66.27	713.33
2	AS PER DOC	66.52	716.00
3	AS PER PATTA	66.52	716.00

FSI AREA DETAILS IN SQ.M & SFT			
S.NO.	FLOOR	F.S.I AREA SQ.M	F.S.I AREA SFT
1	GROUND FLOOR	35.86	386.00
2	FIRST FLOOR	48.03	517.00
3	SECOND FLOOR	48.03	517.00
4	TOTAL	131.92	1420.00
5	F.S.I. ACHIEVED	1.98	

OWNER

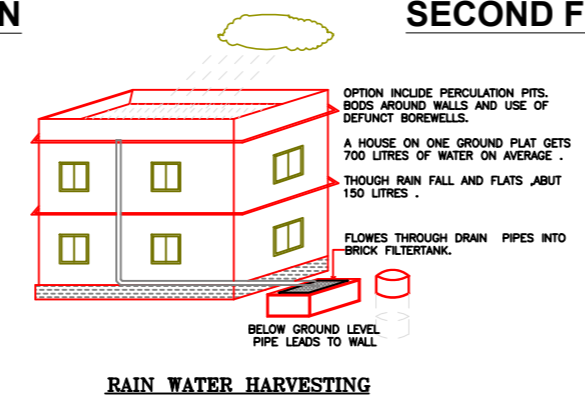
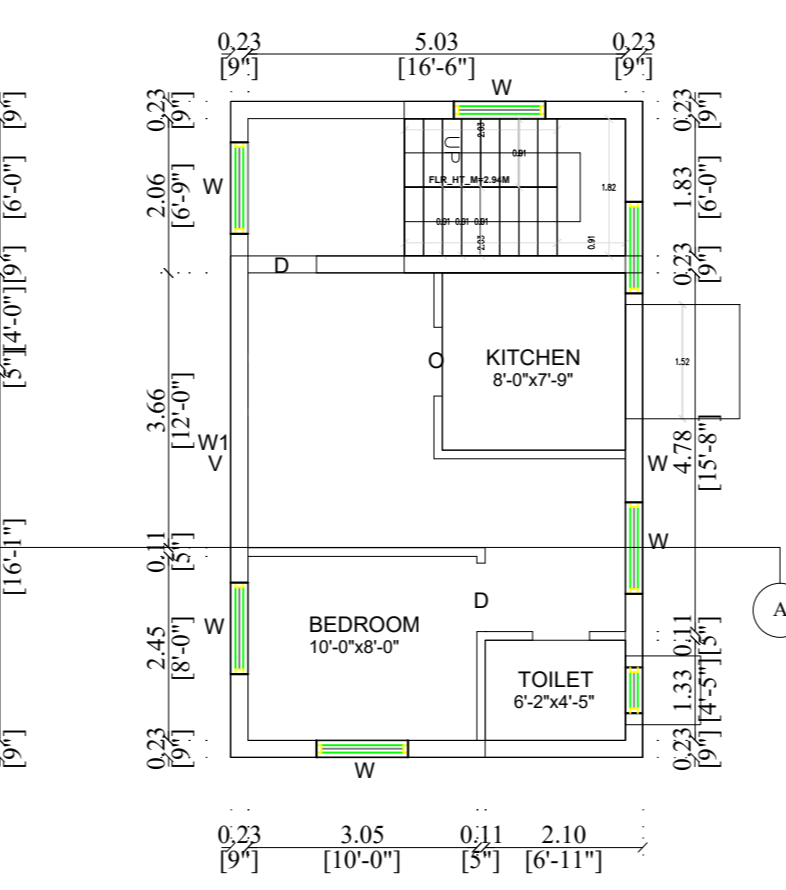
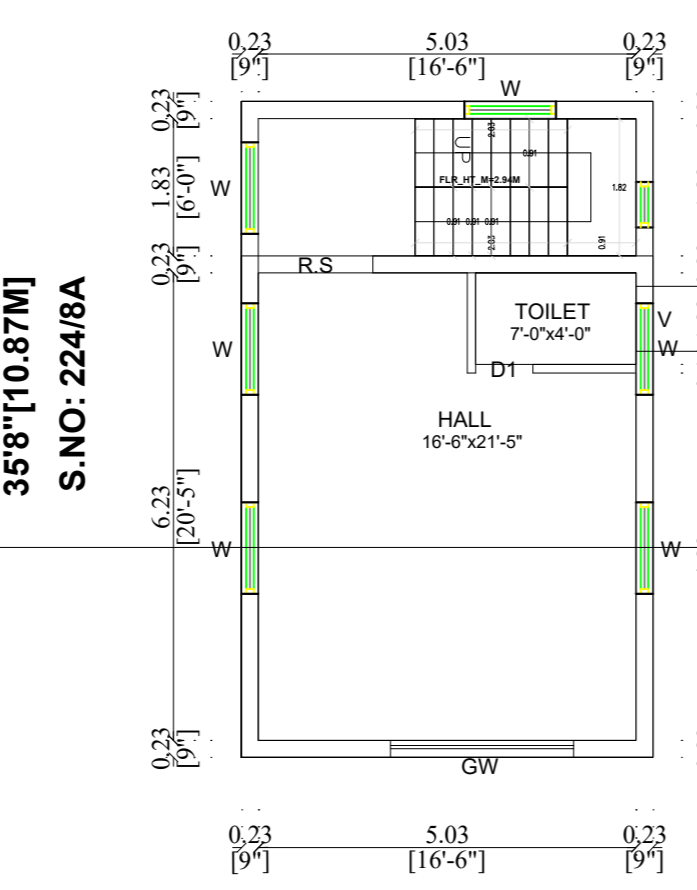
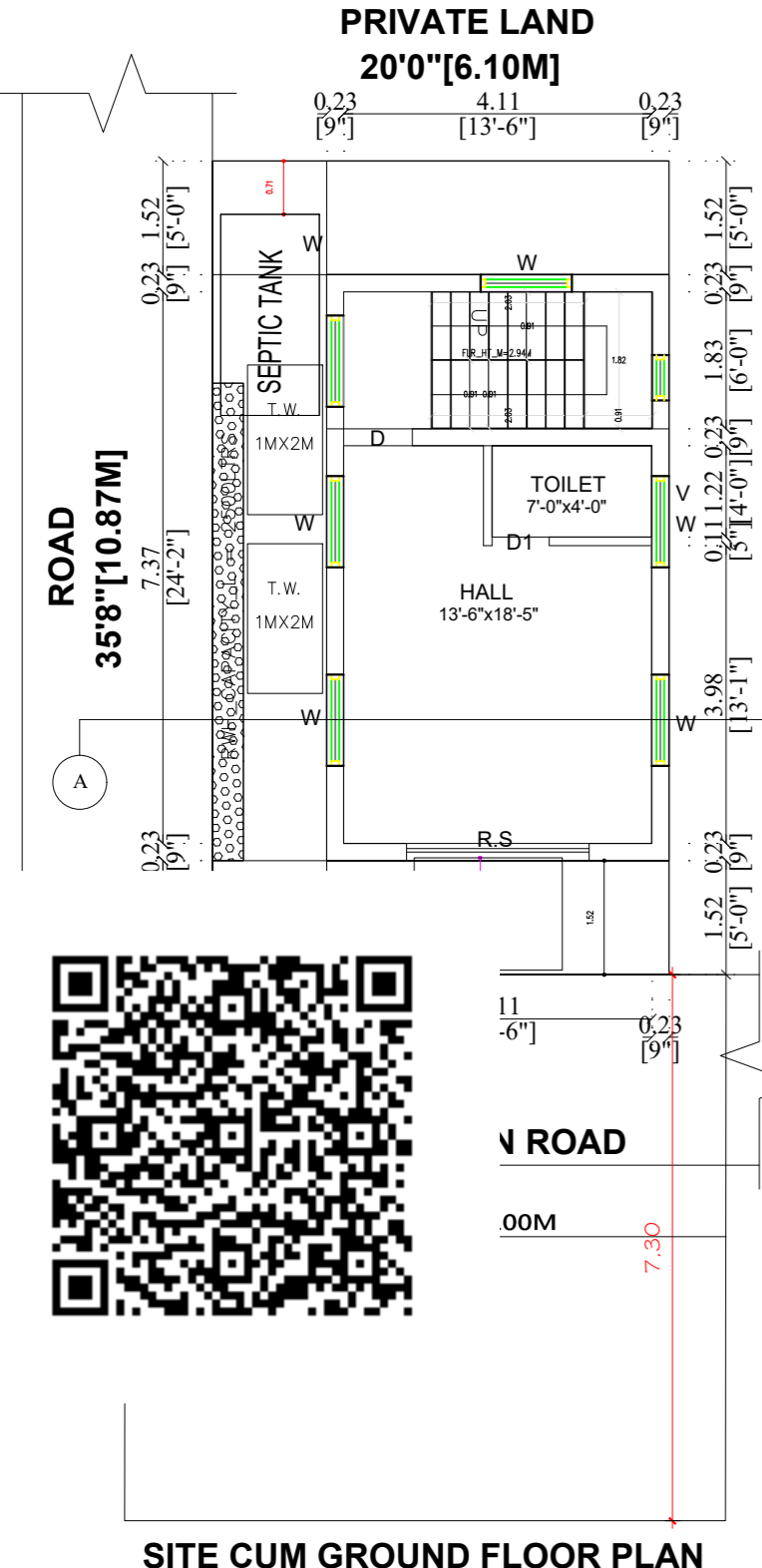
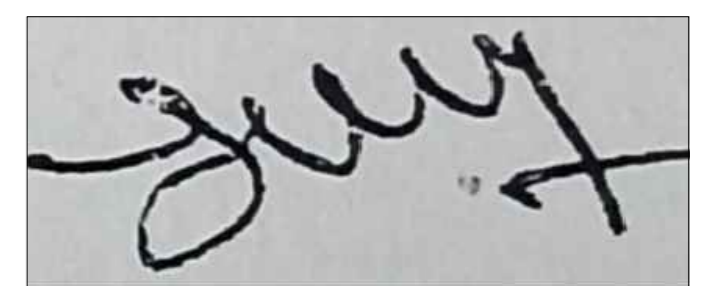

S. Rajkumar  
Er. S. RAJKUMAR  
Licensed Surveyor  
Corporation of Chennai  
LIC No: RE302972019  
CIT Colony, Mylapore, Chennai-600 004.  
Ph : 9994032503, 8667531378

REGISTERED ARCHITECT/ REGISTERED ENGINEER