

PLAN SHOWING THE PROPOSED CONSTRUCTION OF RESIDENTIAL BUILDING AT SURVEY NO: 292/1Apt & 293/65A1A1Apt, PATTA NO : 1425 ,
 PLOT NO : 02, OCEAN FRONT PARAMANKENI VILLAGE AND PANCHAYAT, LATHUR UNION, CHEYYUR TALUK, CHENGALPATTU DISTRICT 603305.

OWNER NAME : M/S.SHANITA HOTEL CHENNAI PRIVATE LIMITED

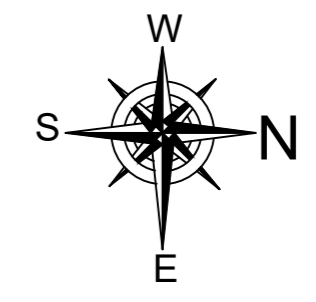

SHEET NO : 1/1

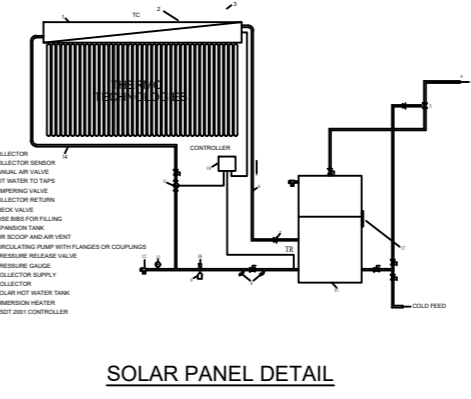
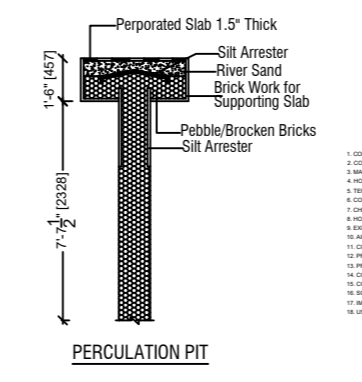
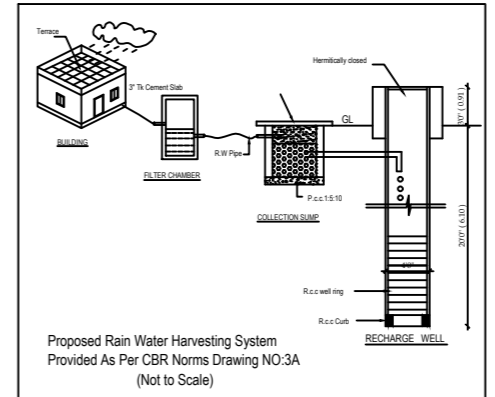
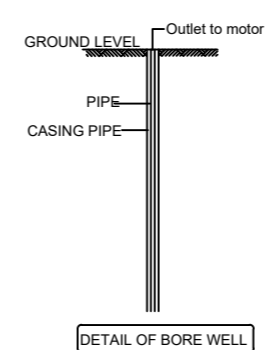
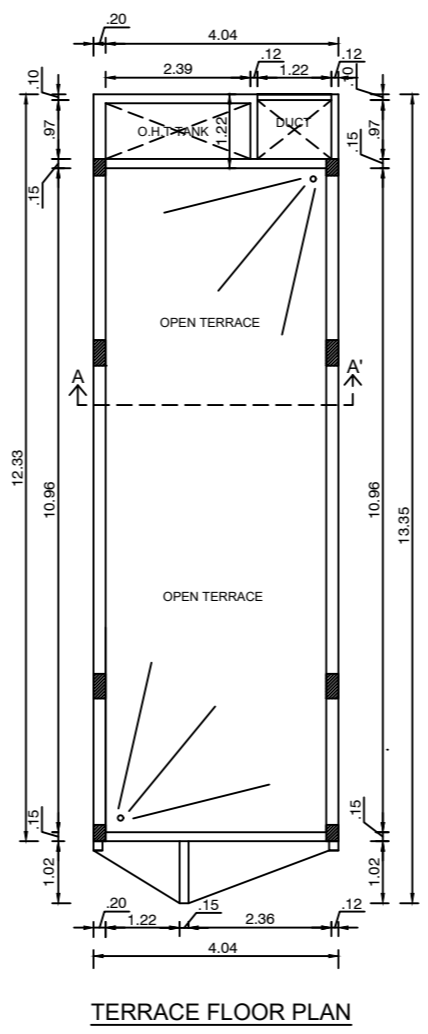
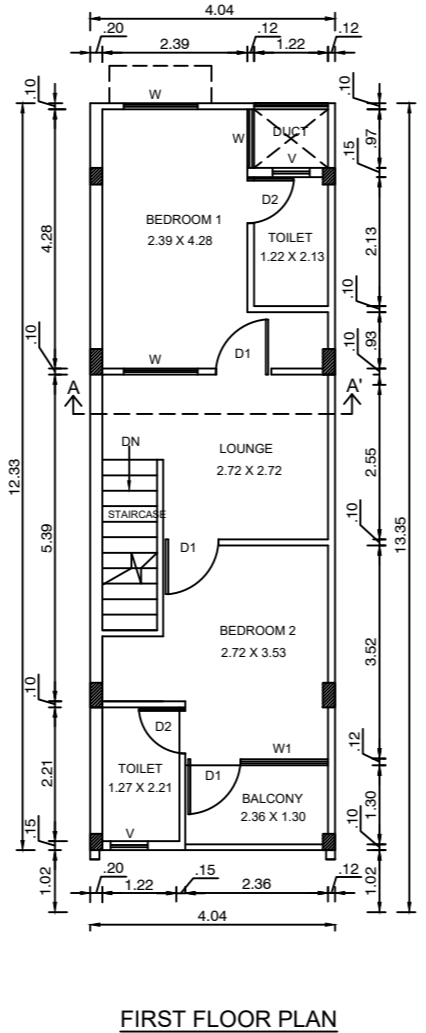
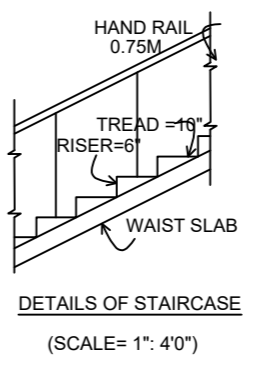
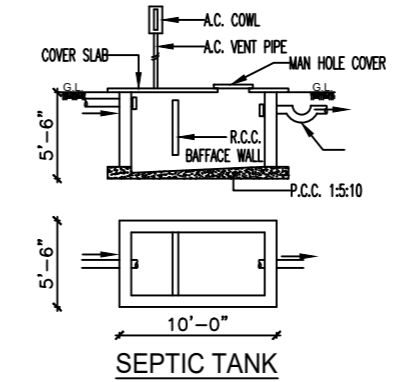
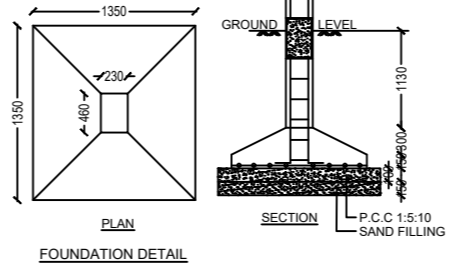
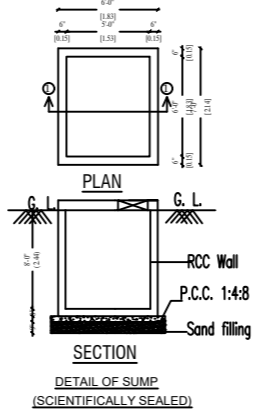
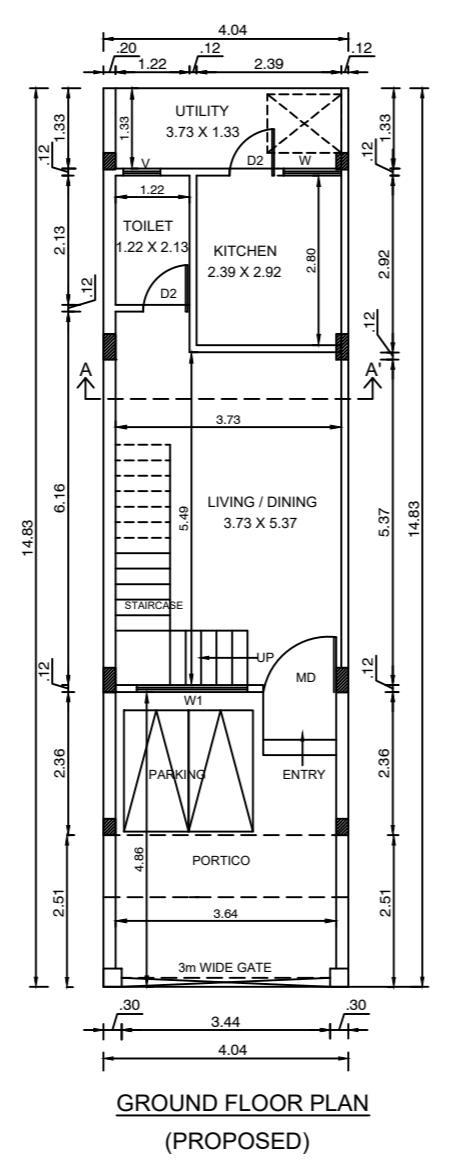
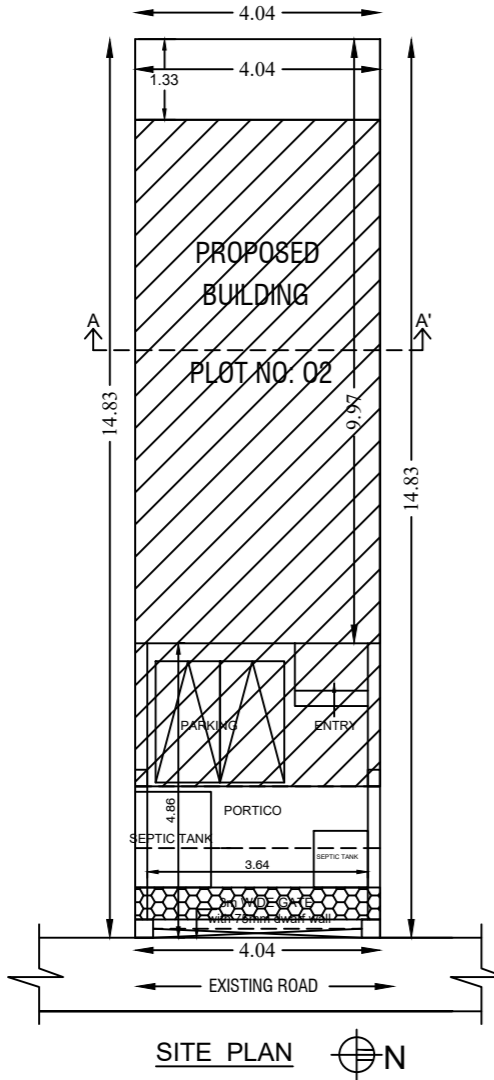
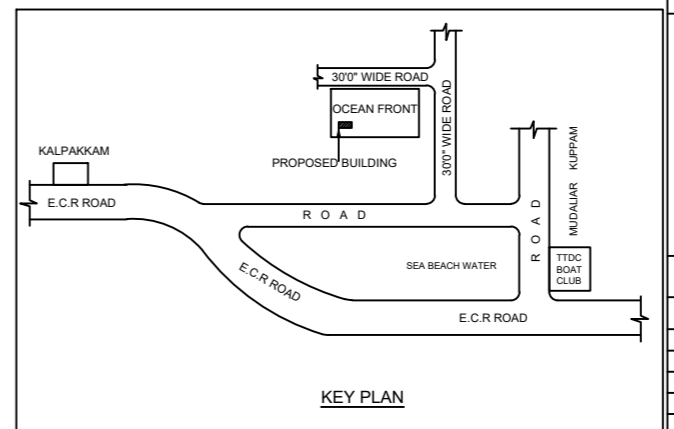
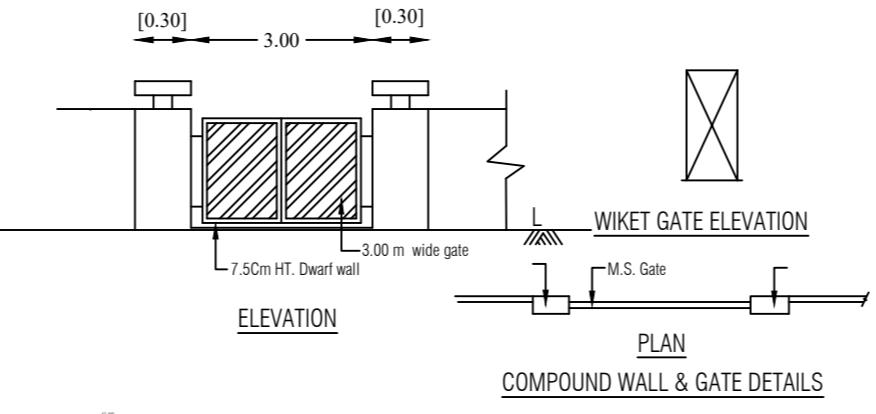
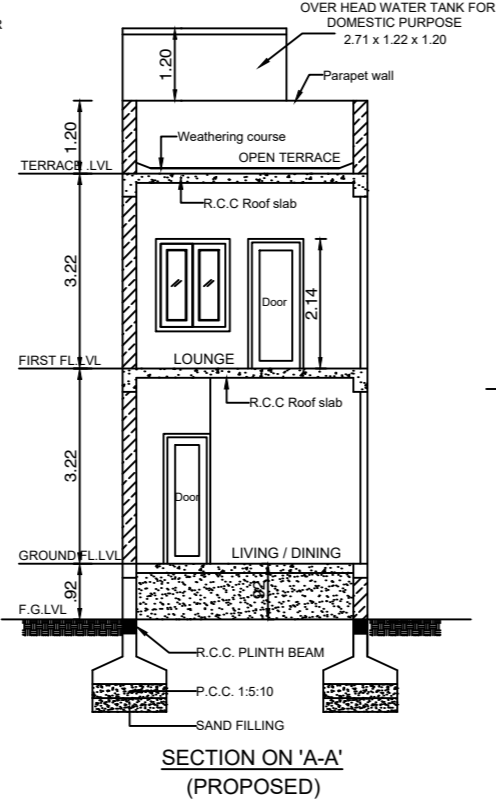
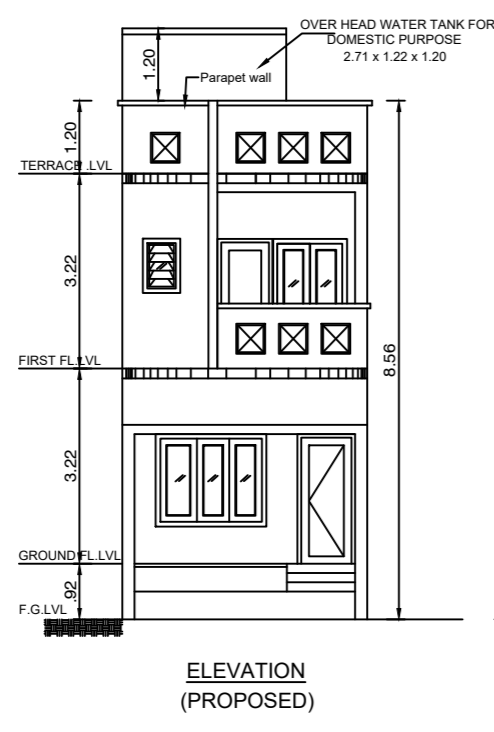

SCHEDULE OF JOINERY

TYPE	DESCRIPTION	IN FEET	IN MM
MD	MAIN DOOR	4'0" x 7'0"	
D1	DOOR	3'0" x 7'0"	
D2	DOOR	2'6" x 7'0"	
W	WINDOW	4'0" x 5'0"	
W1	WINDOW	6'0" x 5'0"	
V	VENTILATOR	2'0" x 4'0"	

SPECIFICATIONS

FOUNDATION : R.C.C COLUMN FOOTING
 BRICK WORK : C.M 1:5 FOR SUPER STRUCTURE
 PLASTERING : C.M 1:5 FOR WALLS & 1:3 FOR CEILING
 FLOORING : MOSAIC FLOORING
 CEMENT PAINT : 2 COAT FOR WALLS & 1 EXTRA COAT FOR CEILING
 R.C.C : 1:2:4 FOR SLABS & LINTELS
 WOOD WORK : ALL WOOD WORKS IN BEST QUALITY TIMBER
 WEATHERING : B.JELLY LIME MORTAR OVER ROOF
 COURSE : SLAB ONE LAYER OF COUNTRY TILES

AREA STATEMENT

S.NO	DESCRIPTION	AREA (SQ.FT.)	AREA (SQ.M.)
1.	PLOT EXTENT	644.86	59.91
2.	GROUND FLOOR AREA	579.43	53.85
3.	FIRST FLOOR AREA	579.43	53.85
4.	TOTAL FLOOR AREA	1158.85	107.70
5.	PLOT COVERAGE	89.88%	
6.	F.S.I	1.79	

COLOUR INDEX

PROPOSED

ROAD/STREET

BOUNDARY/SITE

DEMOLITION

SCALE: 1inch=8feet (or) 1:100
 NORTH POINT
 DATE:

SIGNATURE OF OWNER
 For SHANITA HOTEL CHENNAI PVT. LTD.
 Director.

LICENSED SURVEYOR
 E. A. RAWARMAN B.Tech.,
 EAGLE ASSOCIATE
 Licensed Surveyor Class-II No: 20014-2019
 Greater Chennai Corporation
 No:1 Gangai Amman Koil St, Pavunjar & Post
 Cheyyur Tk, Chengalpattu Dt. Call:98409 79655

