

PLAN SHOWING THE PROPOSED CONSTRUCTION OF A R.C.C RESIDENTIAL BUILDING AT PLOT NOs:26&33, AKSHAYAM CITY, COMPRISED IN S.NO:1450 /111A AND 1450 /1B1 AS PER PATTA NOS.6745 & 6753, AS PER PATTA NEW S.NOs:1450/26,30 & 1450/29 OF THAIYUR-B VILLAGE, THIRUPORUR PANCHAYAT UNION THIRUPORUR TALUK AND CHENGALPET DISTRICT.

LAND OWNER : M.KOTTAIYAN

NOTE: DTCP APPROVED LAYOUT NO:DTCP NO-47(R) 2017.

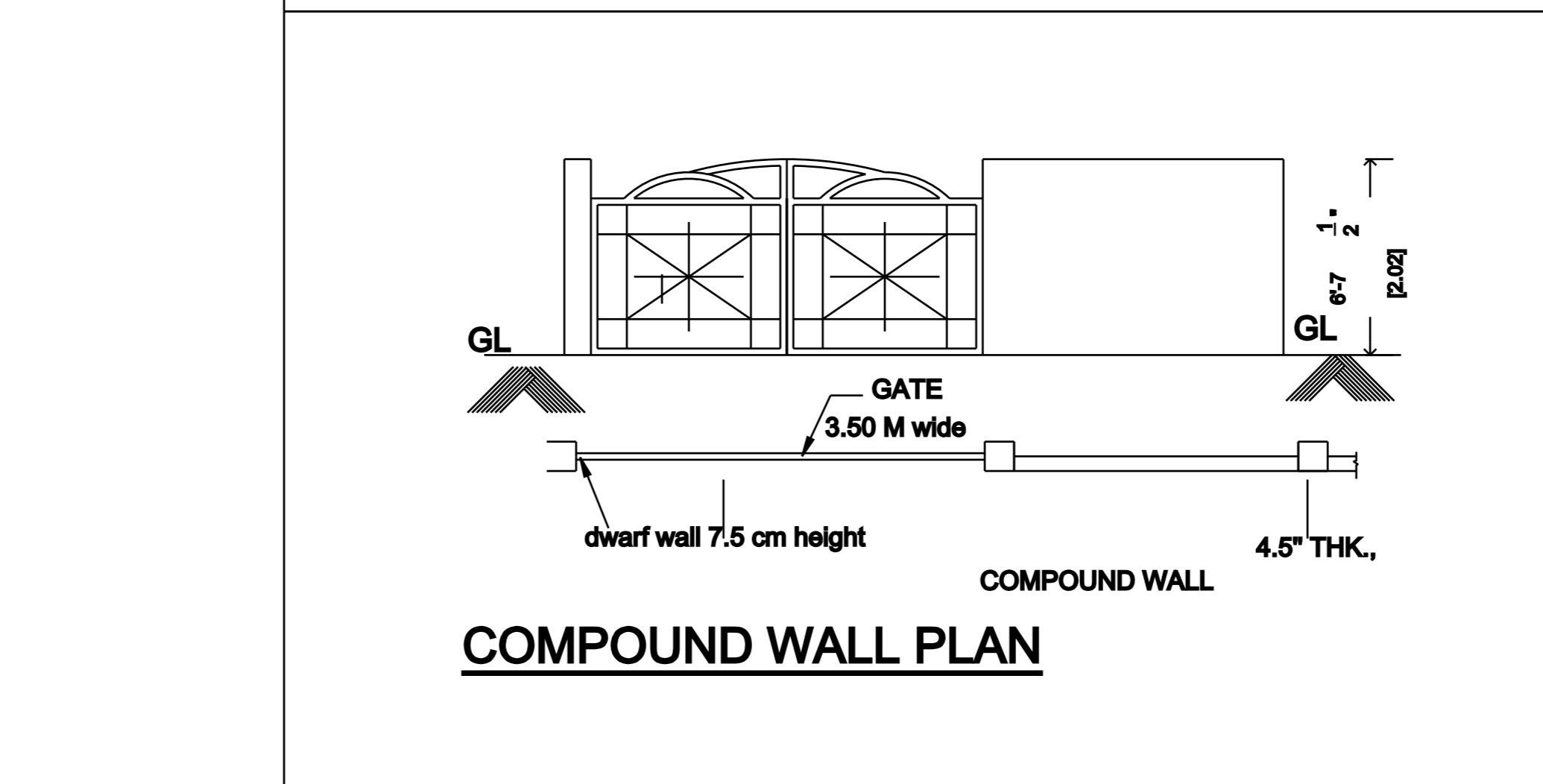
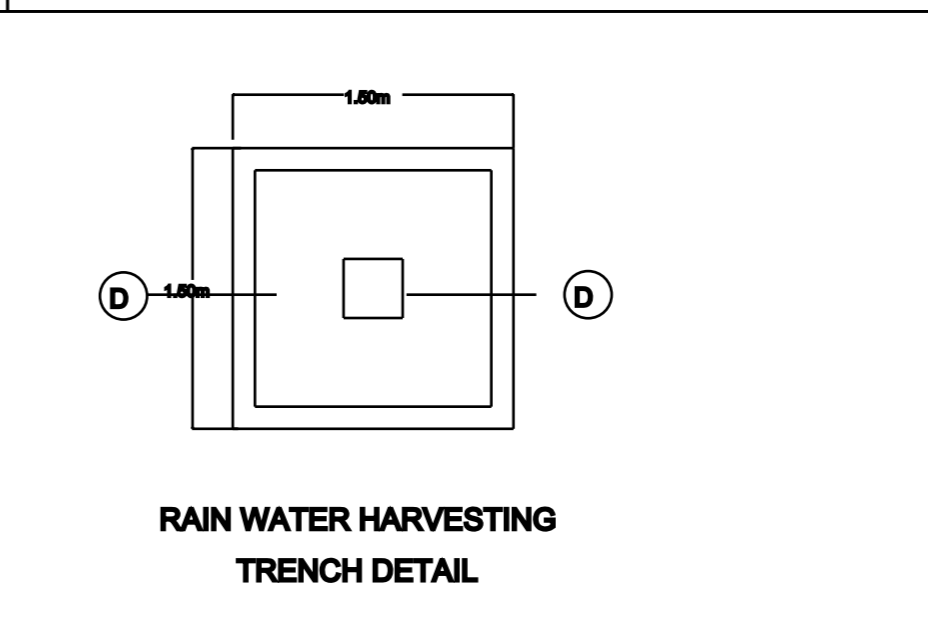
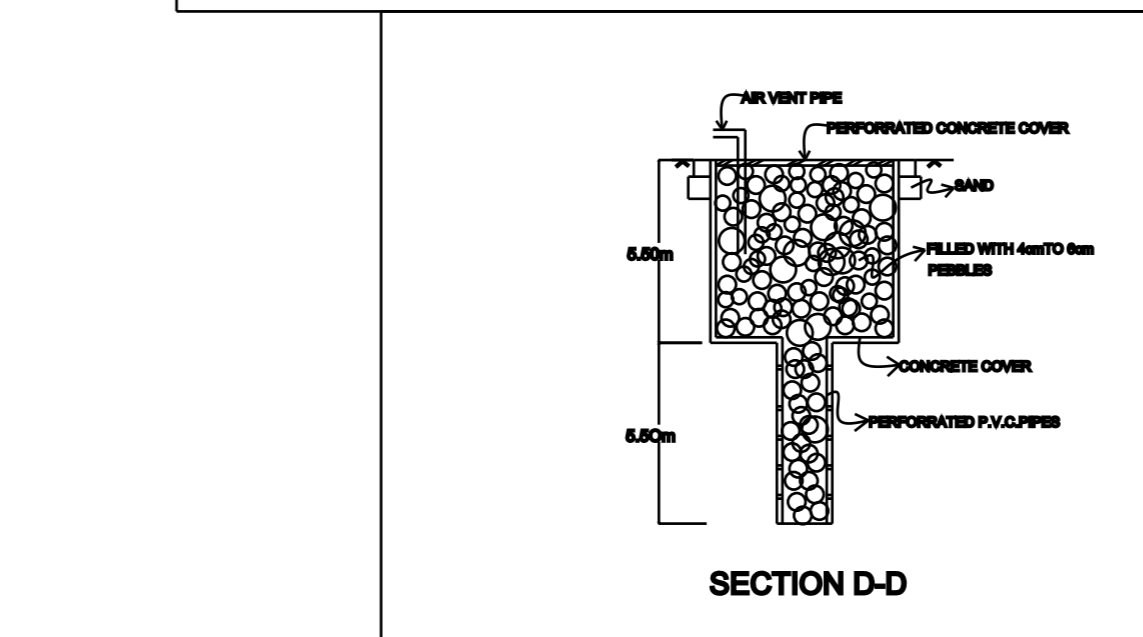
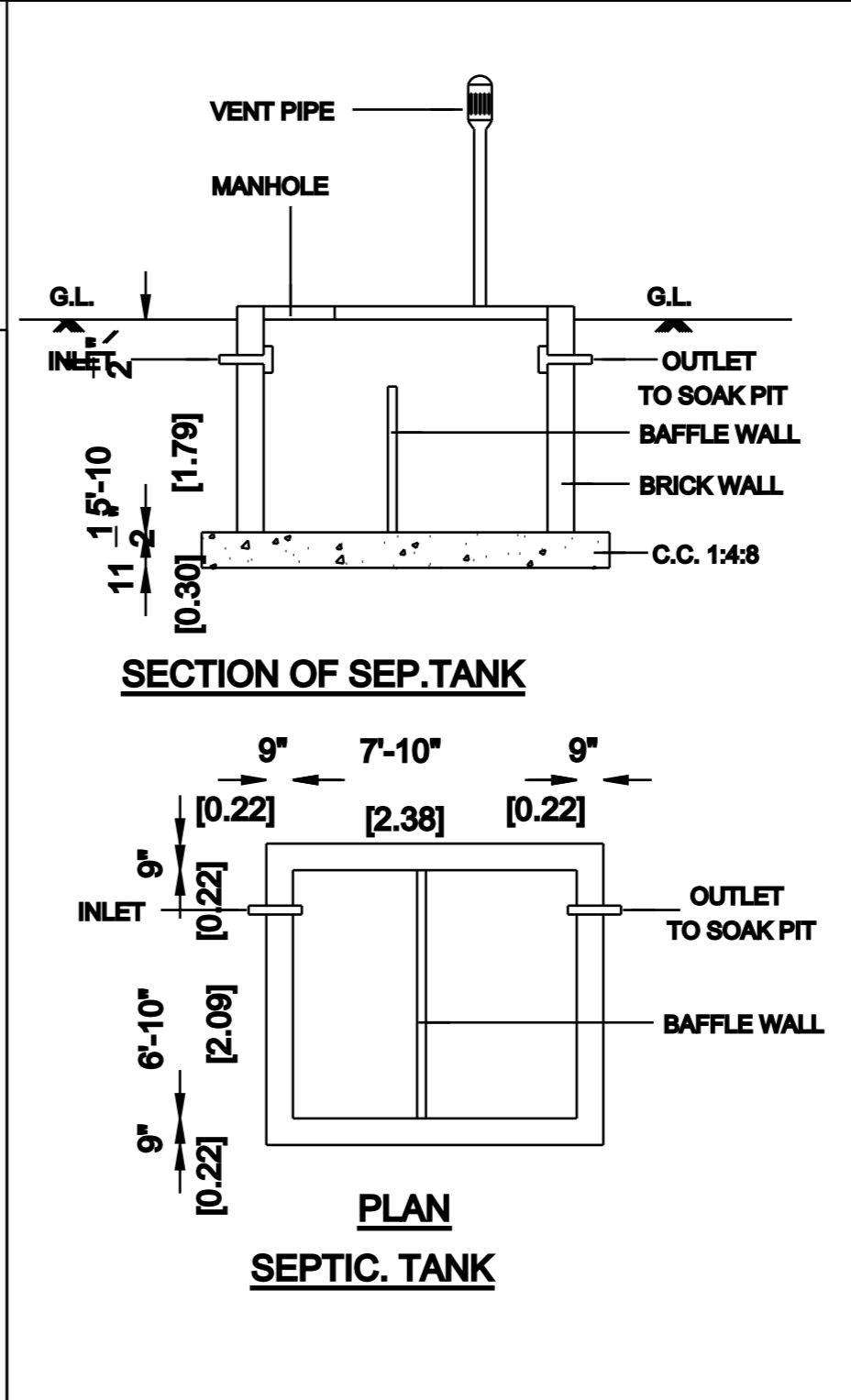
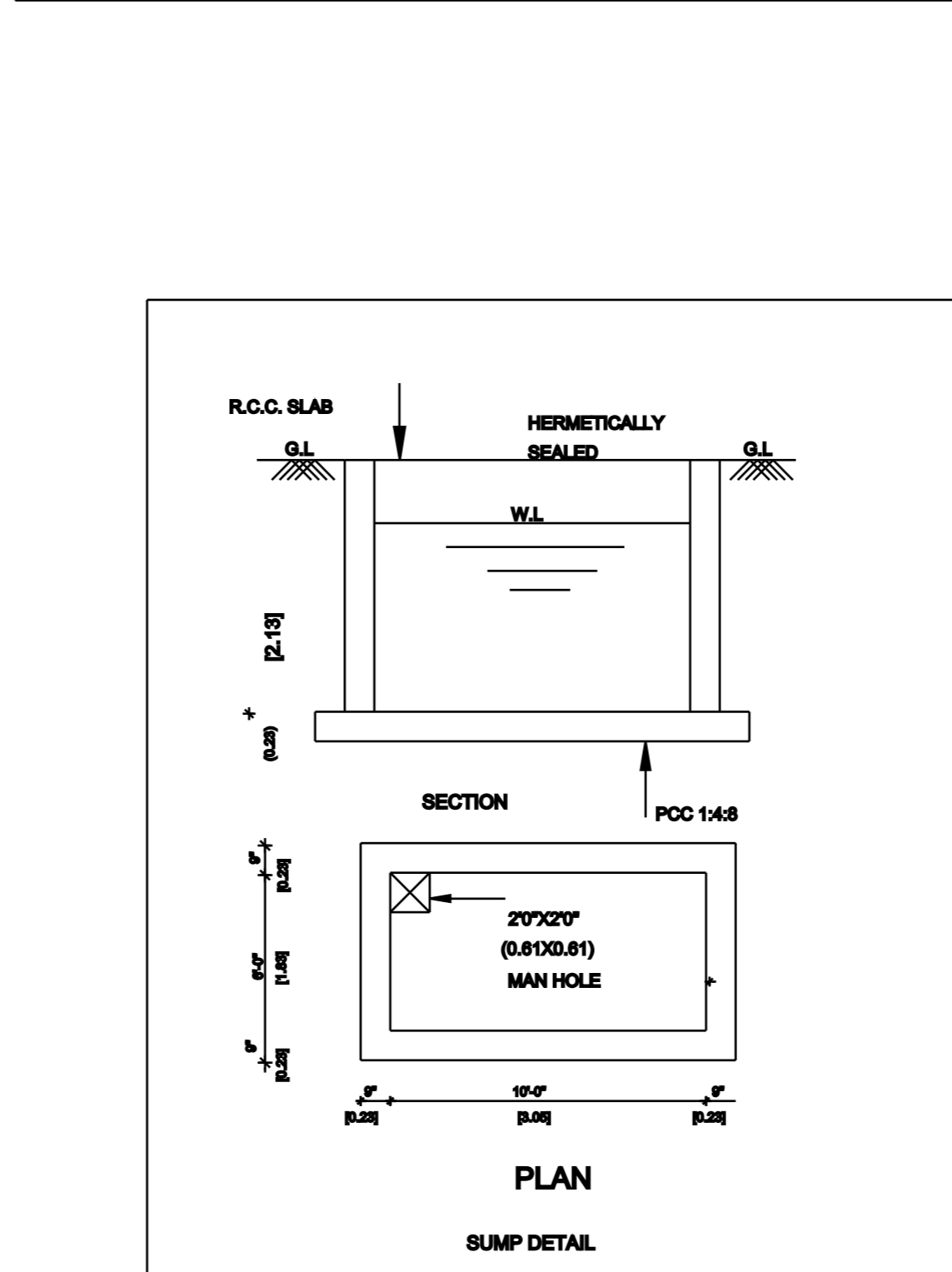
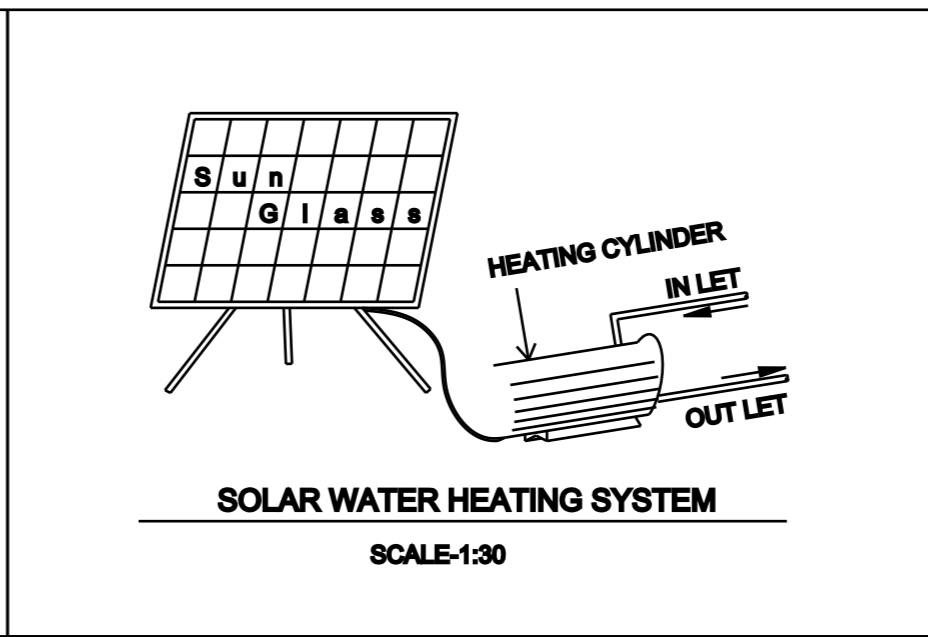
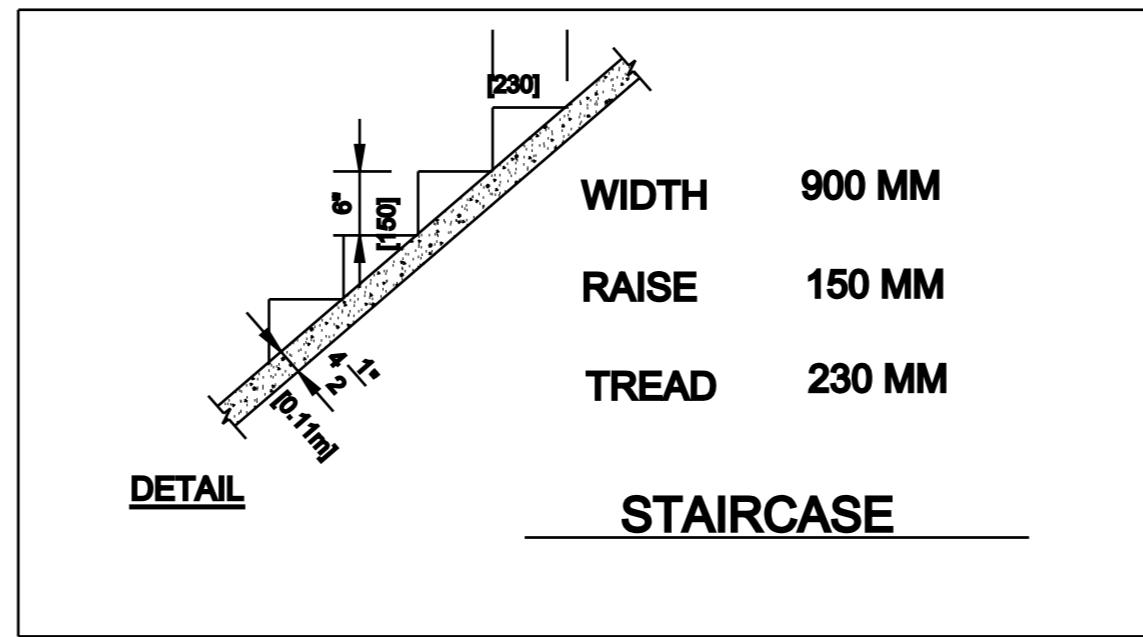
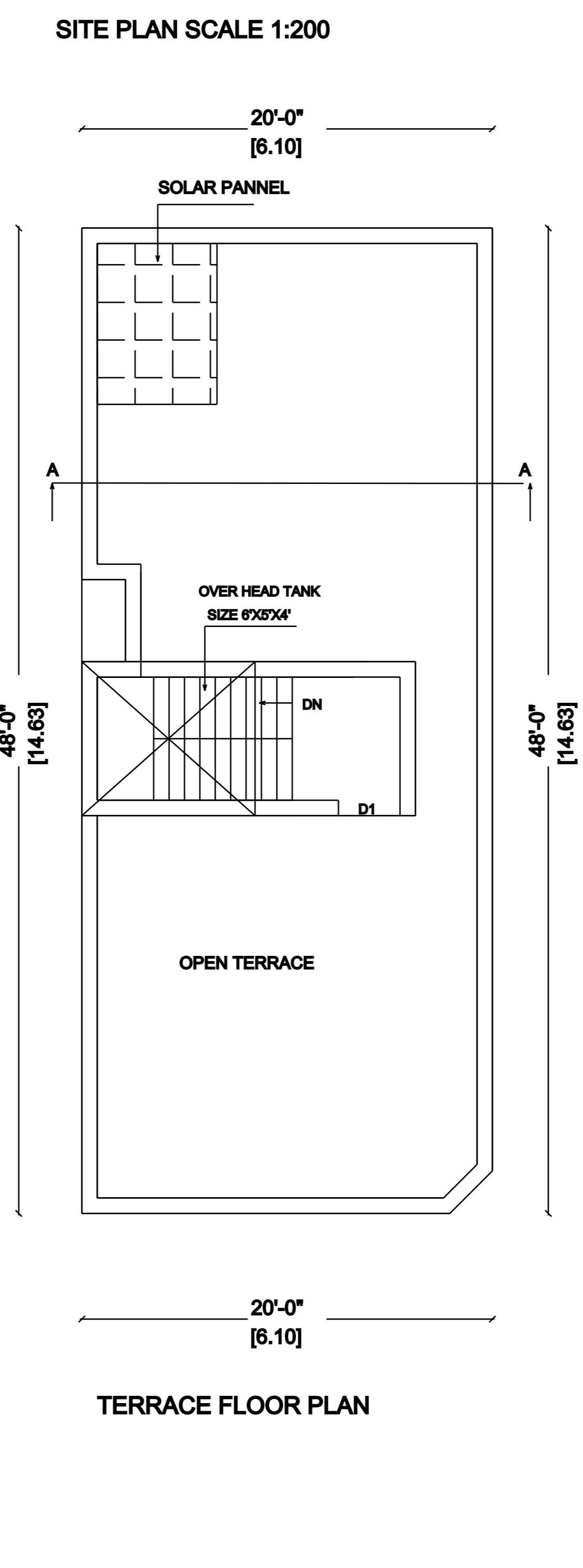
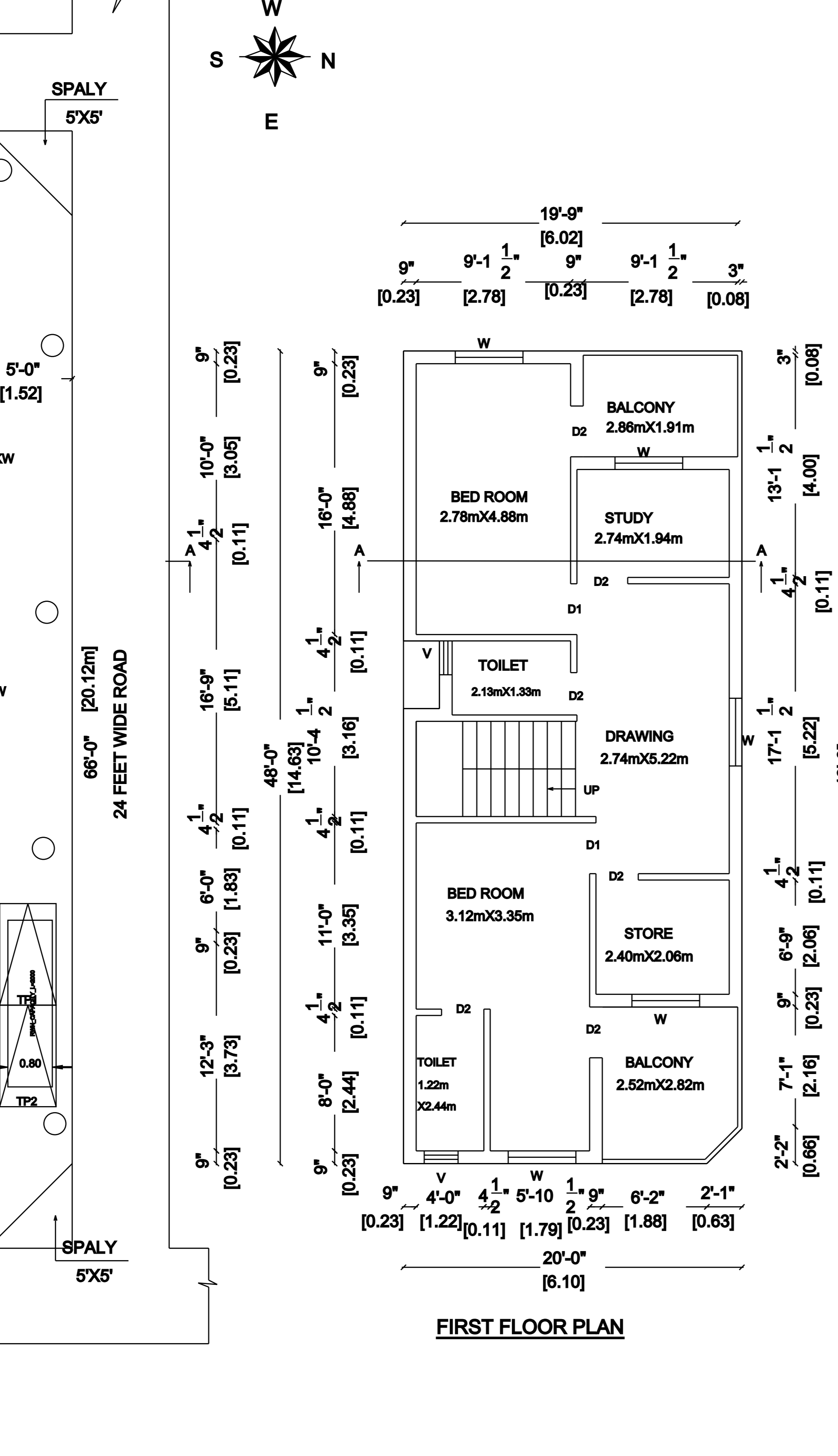
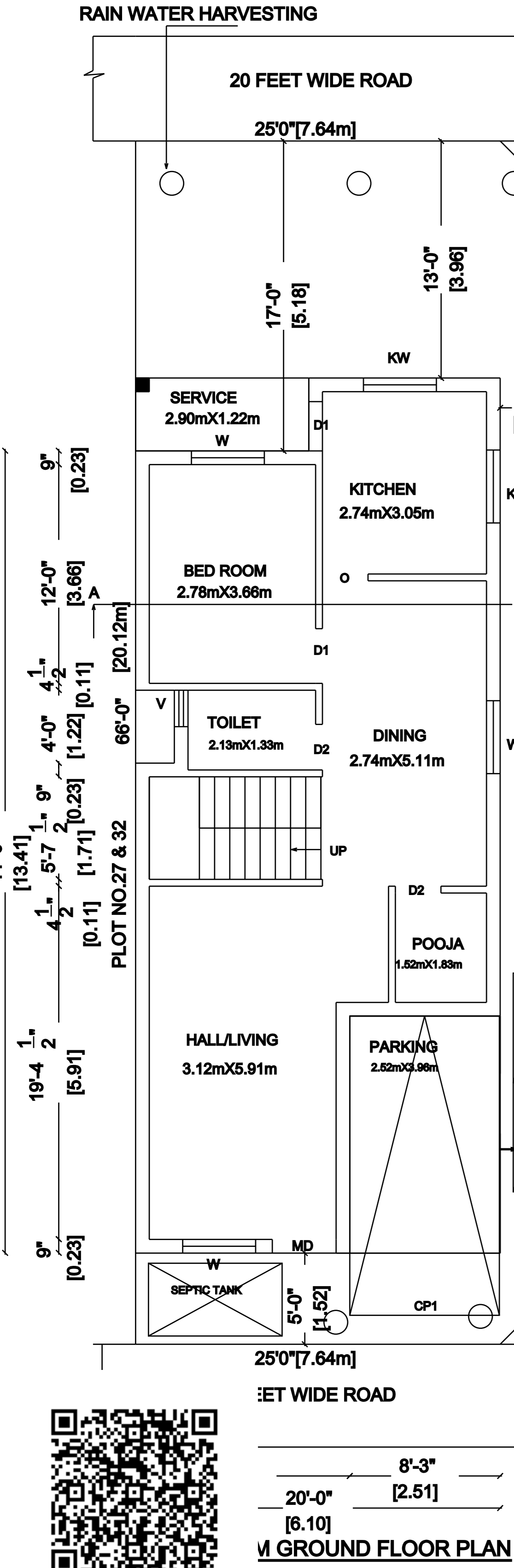
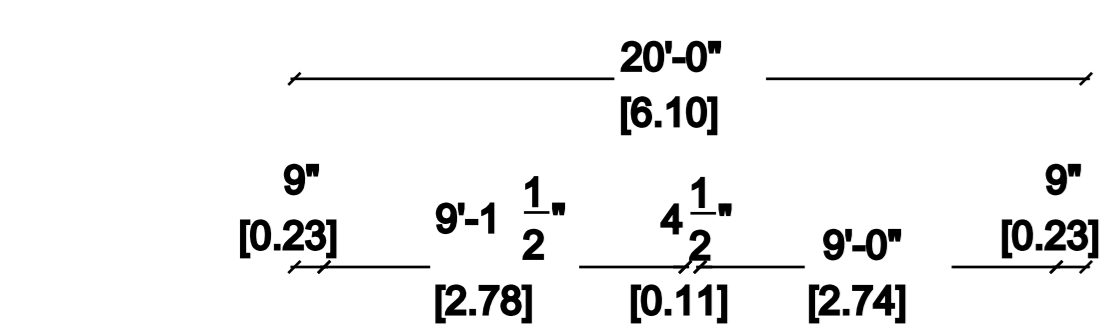
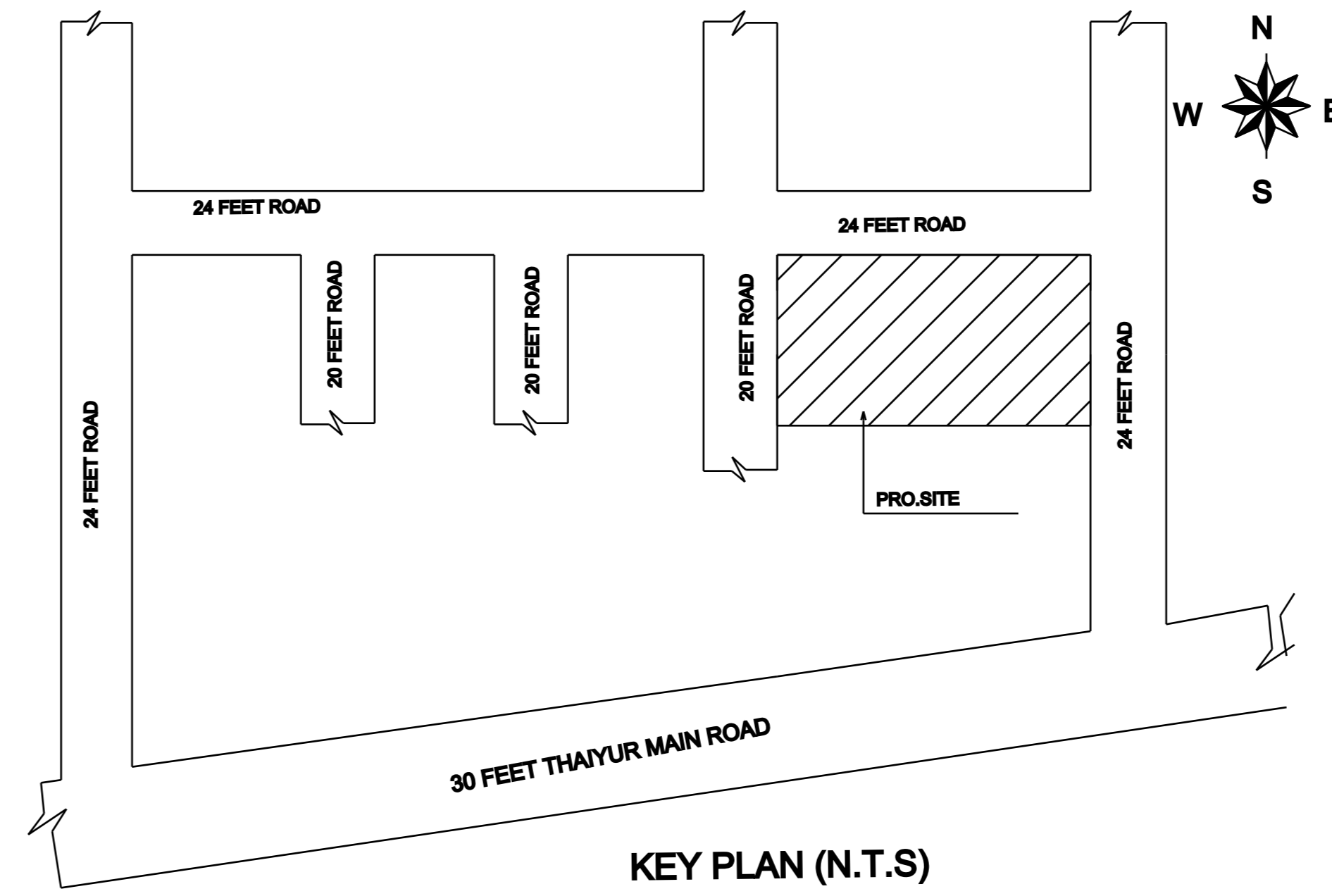
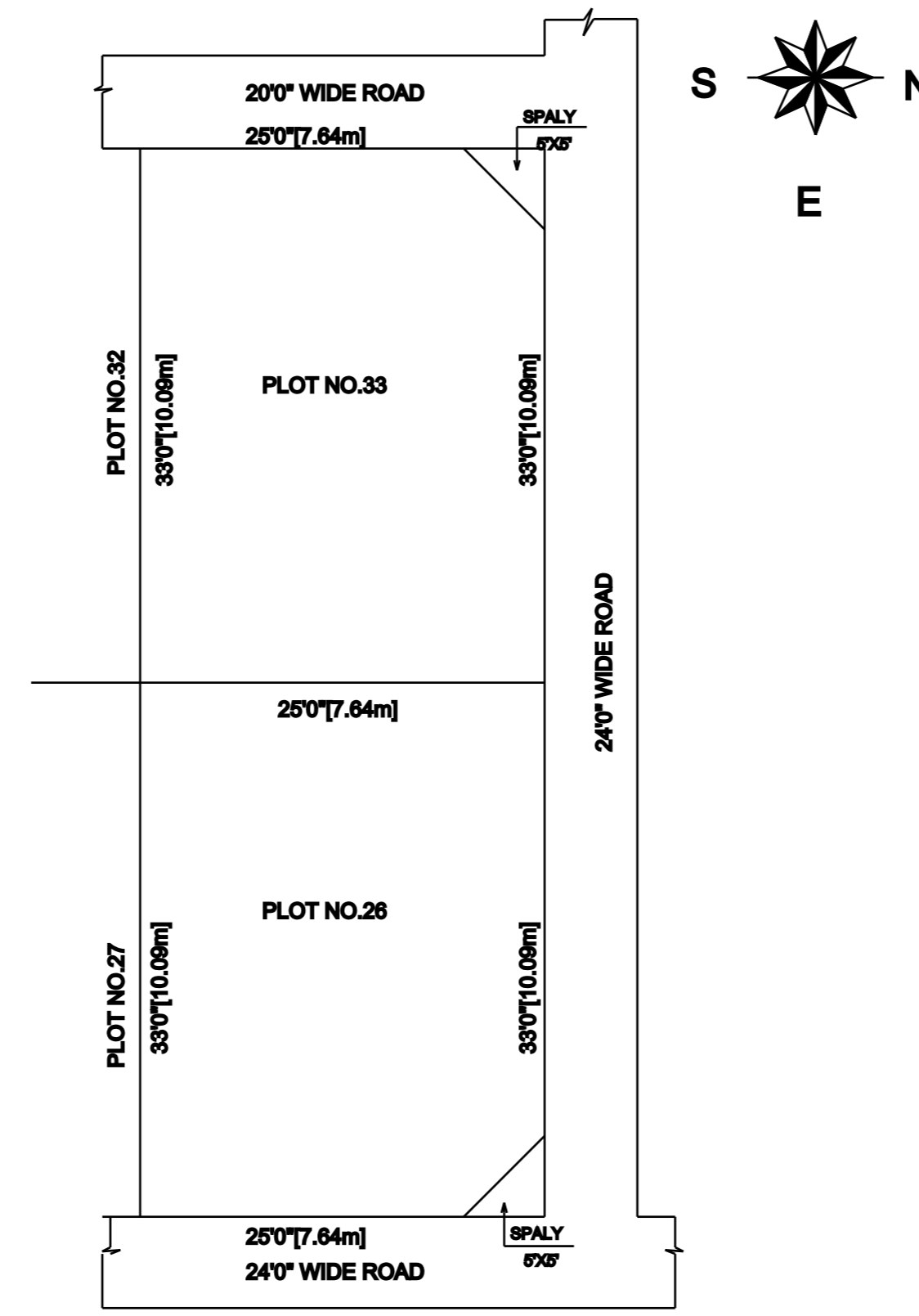
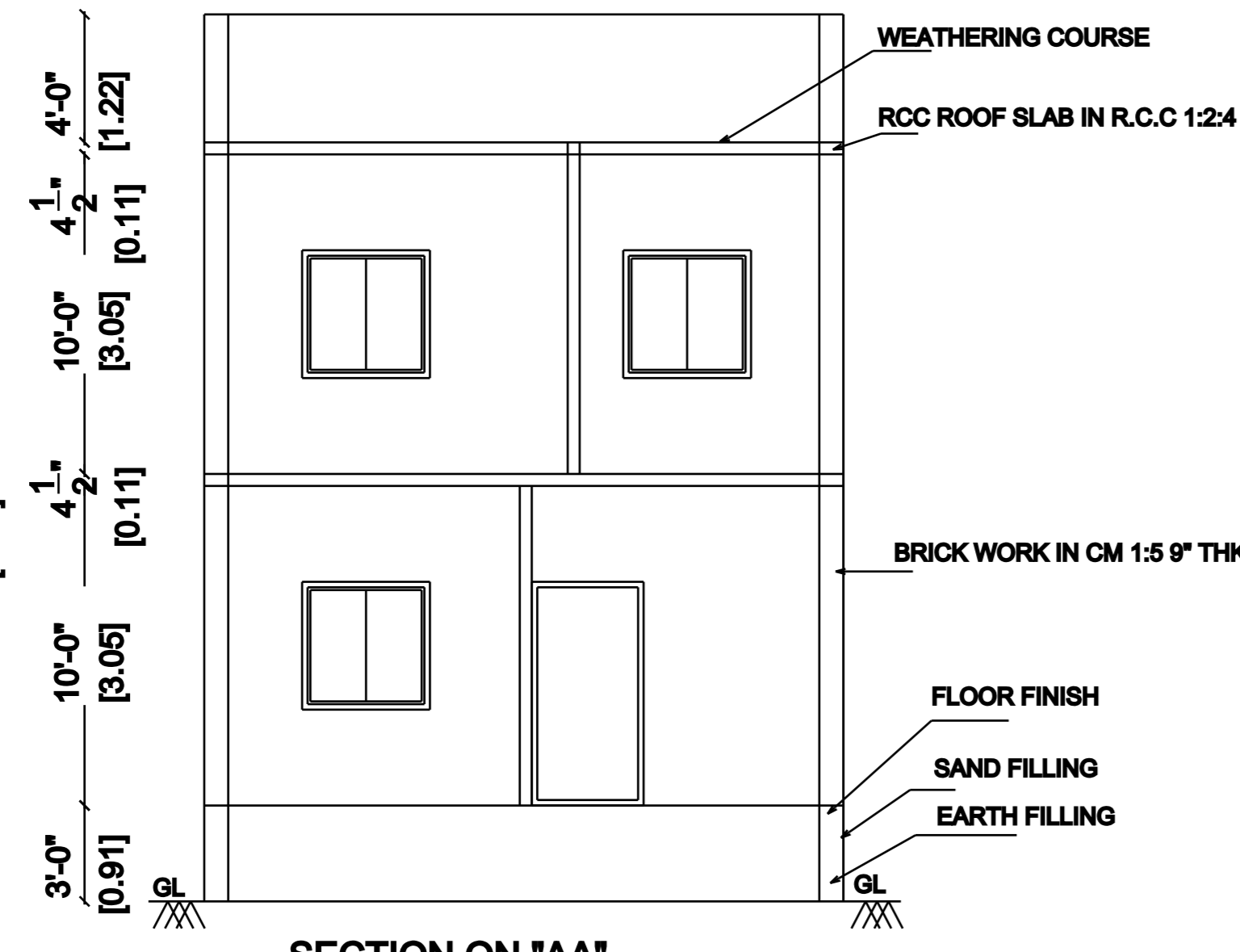
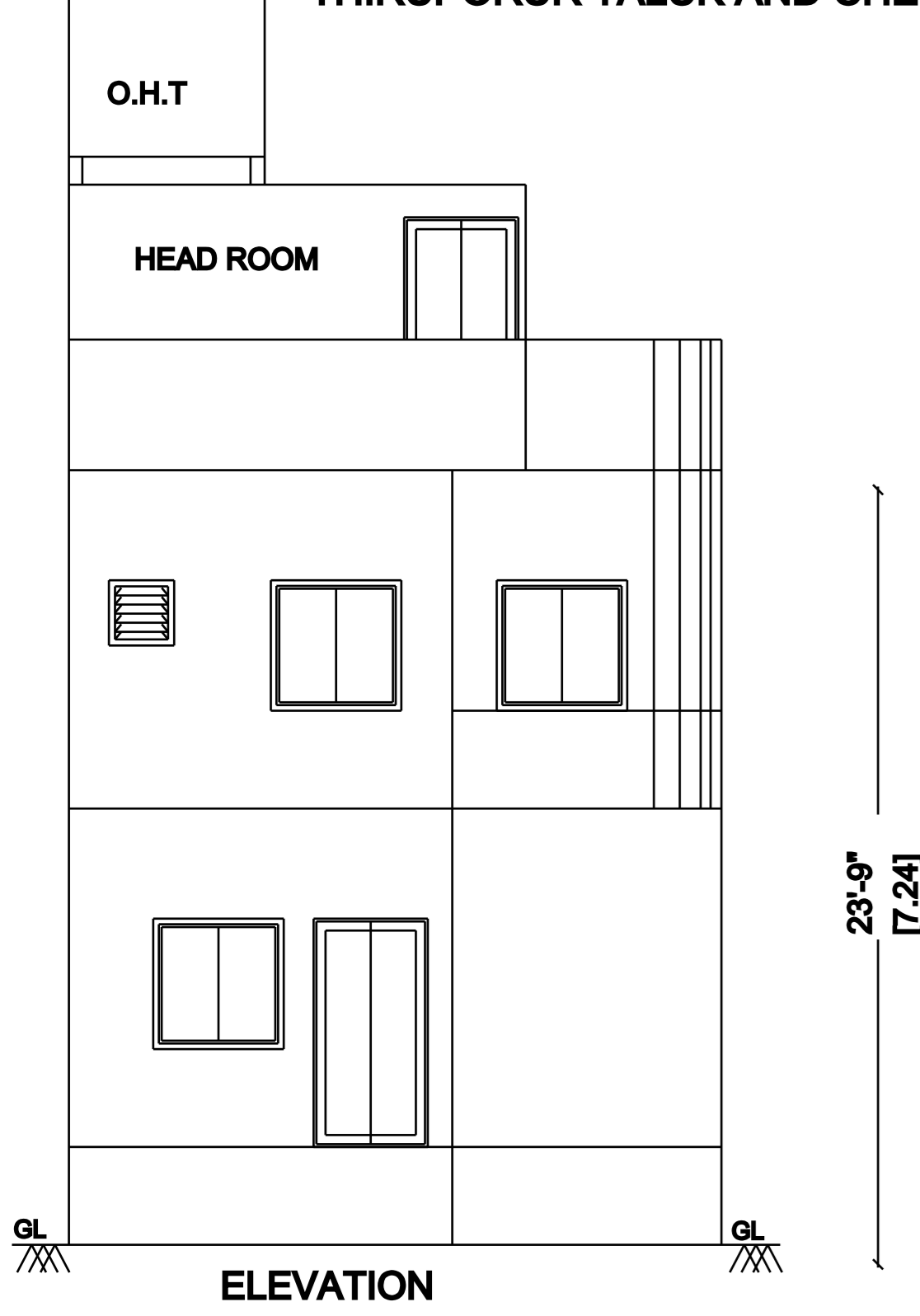

**JOINERY DETAILS:**

DESCRIPTION	FEET	METRE
DOOR M.D	3'6"x7'0"	1.00 x 2.13
DOOR D1	3'0"x7'0"	0.91 x 2.13
DOOR D2	2'6"x7'0"	0.76 x 2.13
WINDOW W	4'0"x4'0"	1.22 x 1.22
VENTILATOR V	2'0"x3'0"	0.61 x 0.91

**COLOUR INDEX:**

ROAD	
BOUNDARY	
PROPOSED	

AREA STATEMENT	SQ.FT	SQ.M
PLOT NO.26	825.00	76.67
PLOT NO.33	825.00	76.67
TOTAL PLOT AREA	1650.00	153.34
PRO. GROUND FLOOR AREA	845.00	78.46
PRO. FIRST FLOOR AREA	949.00	88.23
TOTAL BUILT UP AREA	1794.00	166.69
PARKING AREA (NON FSI)	107.00	9.97
HEAD ROOM AREA (NON FSI)	122.00	11.33

F.S.I = 1.08 PLOT COVERAGE=57%

SCALE 1" = 8'-0" (1:100)

OWNER SIGNATURE:

*E.K. Meenakshi*  
**Er.K. MEENAKSHI, D.C.E.,**  
 REGISTERED ENGINEER GRADE - III (RE)  
 REG. No. CGLDIST/RE/Gr - III/2020/11/019  
 LICENSED SURVEYOR  
 NANDHIVARAM - GUDUVANCHERI MUNICIPALITY  
 UDAYA PLANNERS  
 PLOT No. 48, MOHANAPRIYA NAGAR  
 GUDUVANCHERI - 603 202.  
 Email : udayaplanners@gmail.com  
 CELL : 9445359501, 9600167896

LICENSED SURVEYOR