

PLAN SHOWING THE PROPOSED CONSTRUCTION RESIDENTIAL BUILDING AT S.No.206/1, PATTA No.2971, THIRUVIDANTHI VILLAGE & PANCHAYAT, THIRUPORUR TALUK & PANCHAYAT UNION, CHENGALPATTU DISTRICT.

OWNER NAME:-1.Mr.SUNDER RAMAN.
2.Mrs.SHOBHA SUNDER RAMAN.

SCALE:-1 INCH = 8 FEET

NITHYAKALYANA PERUMAL TEMPLE & ARUMUGAM PROPERTY
148'3"(45.20m)

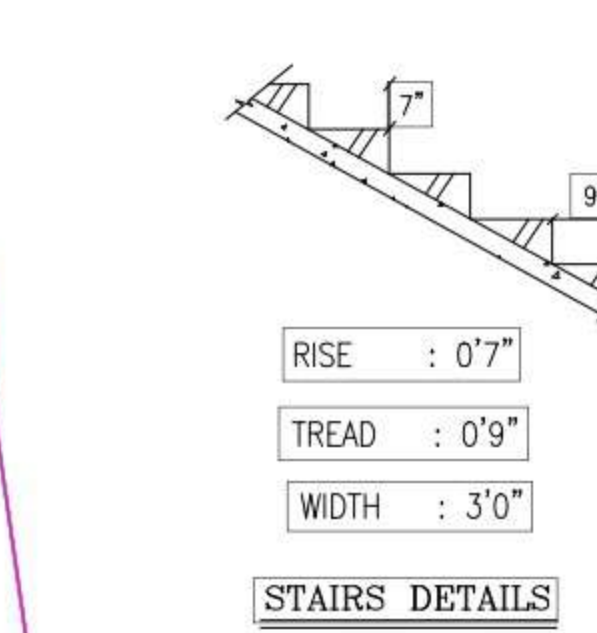
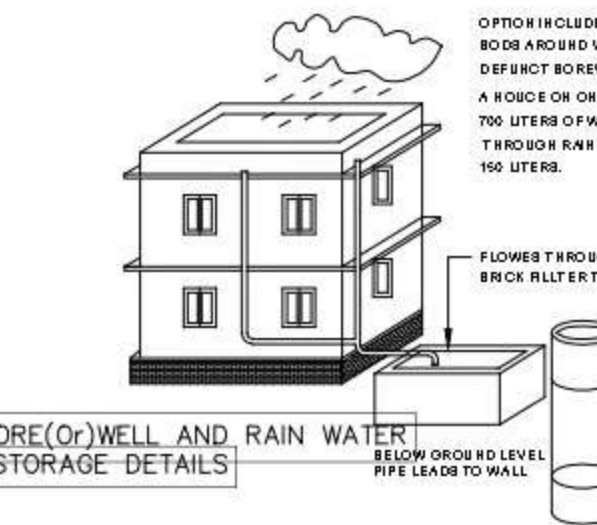
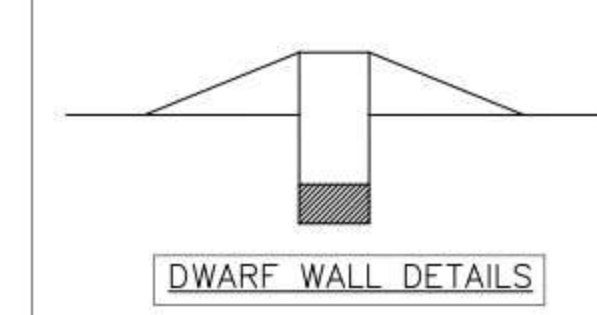
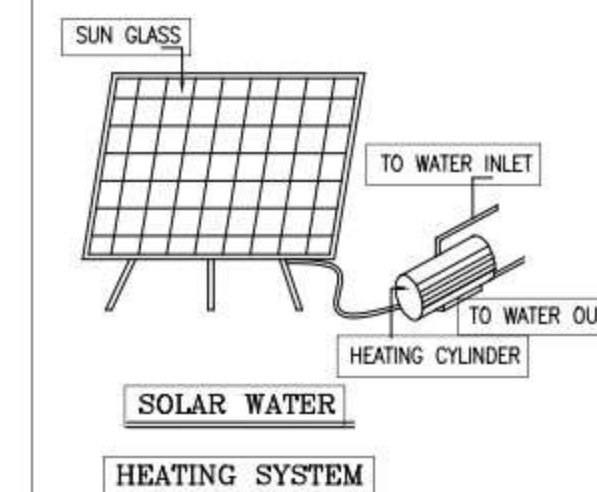
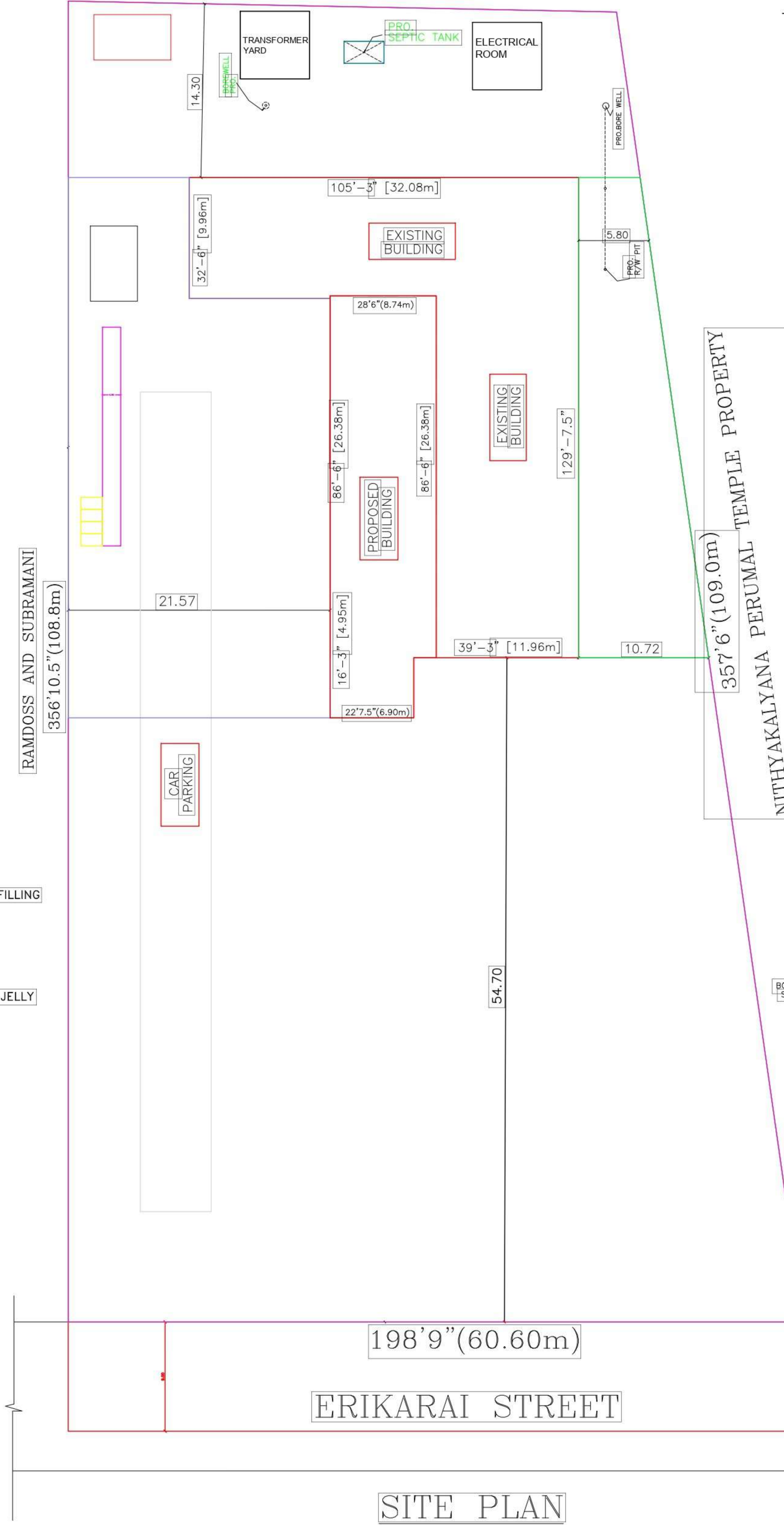
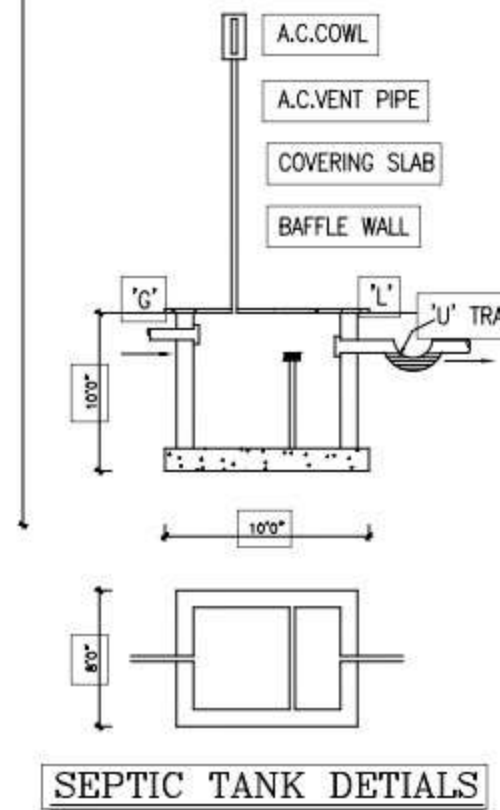
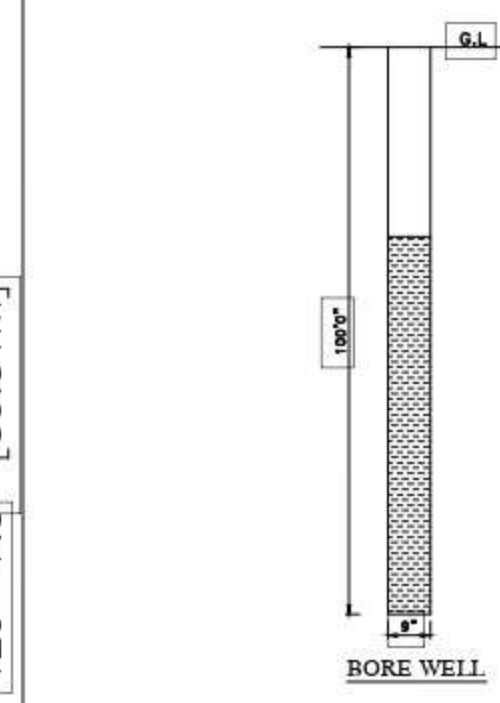
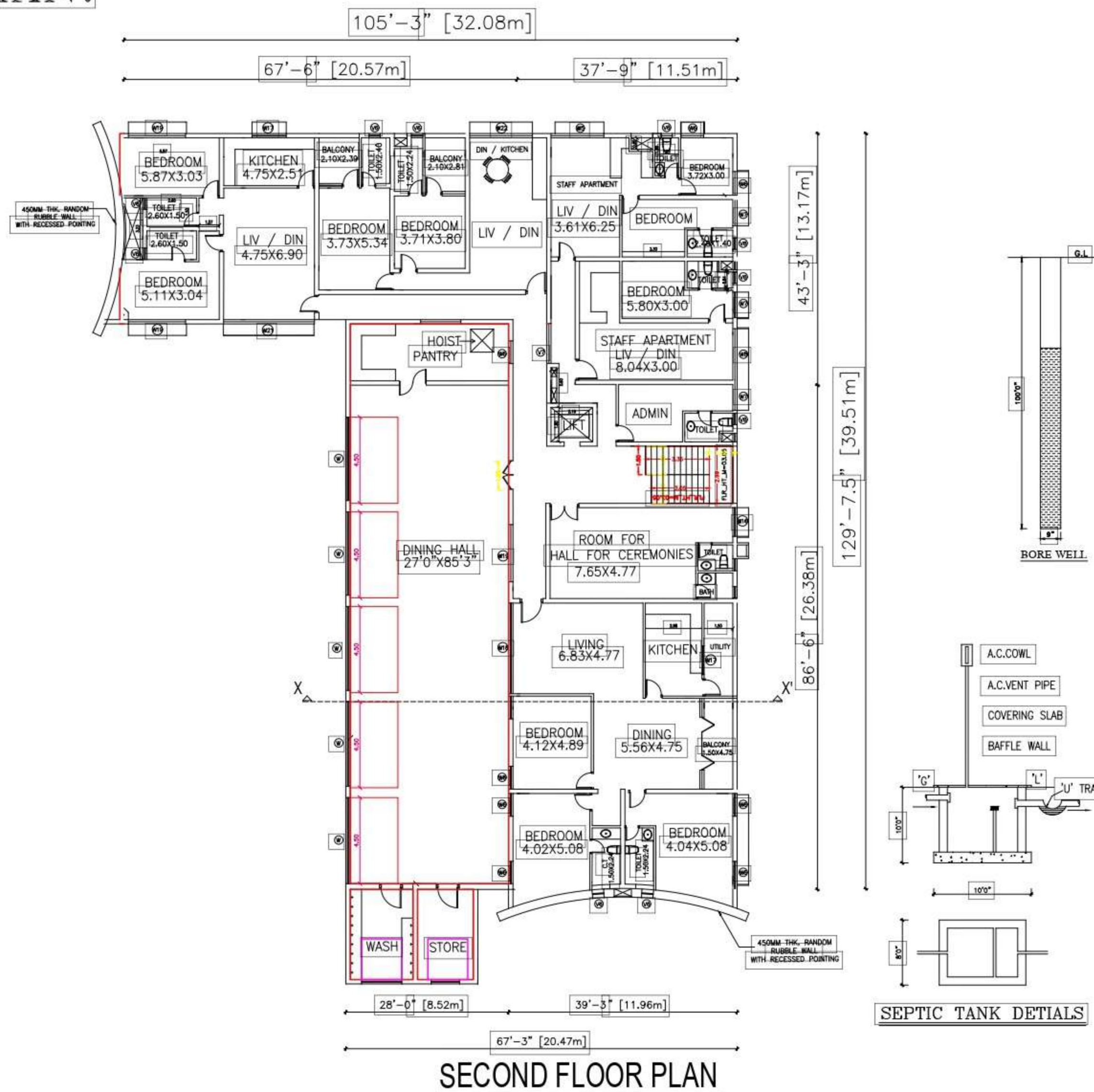
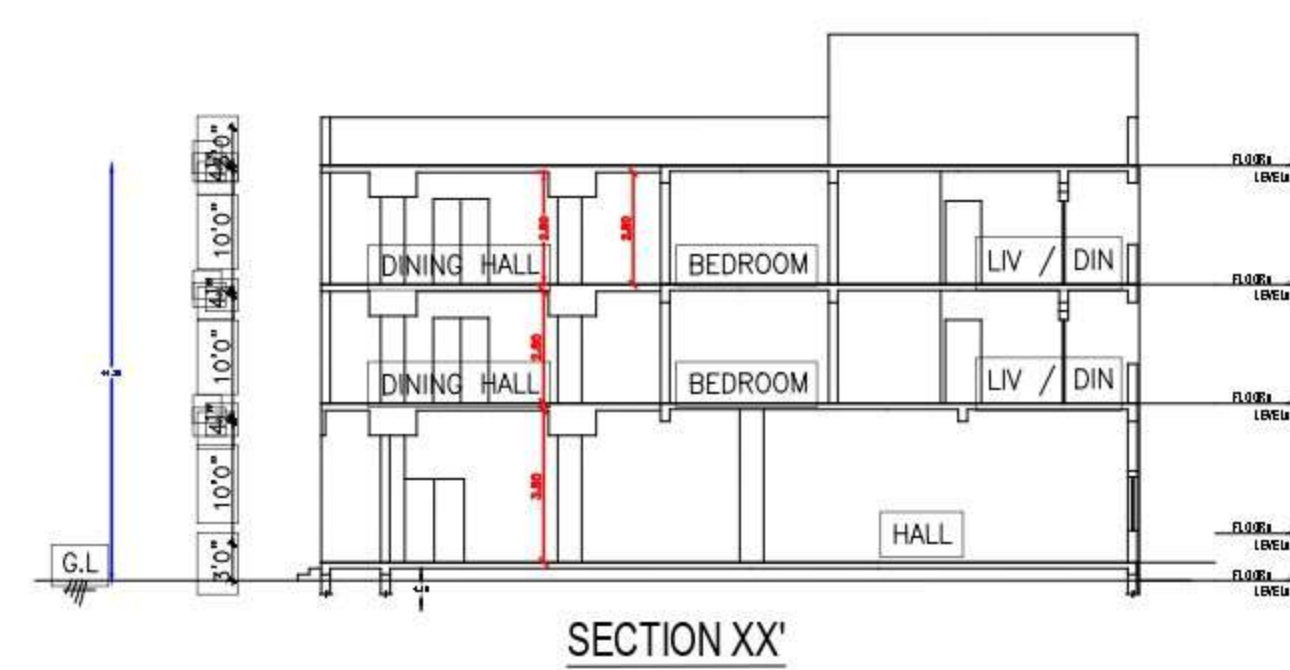
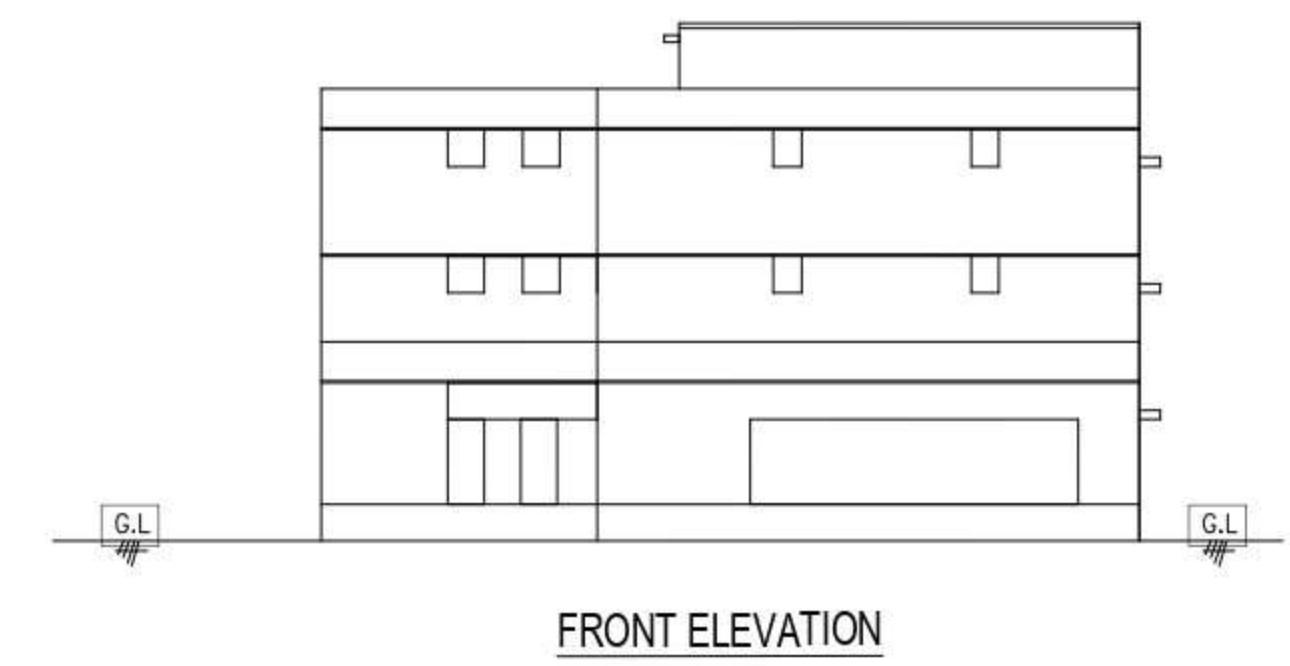
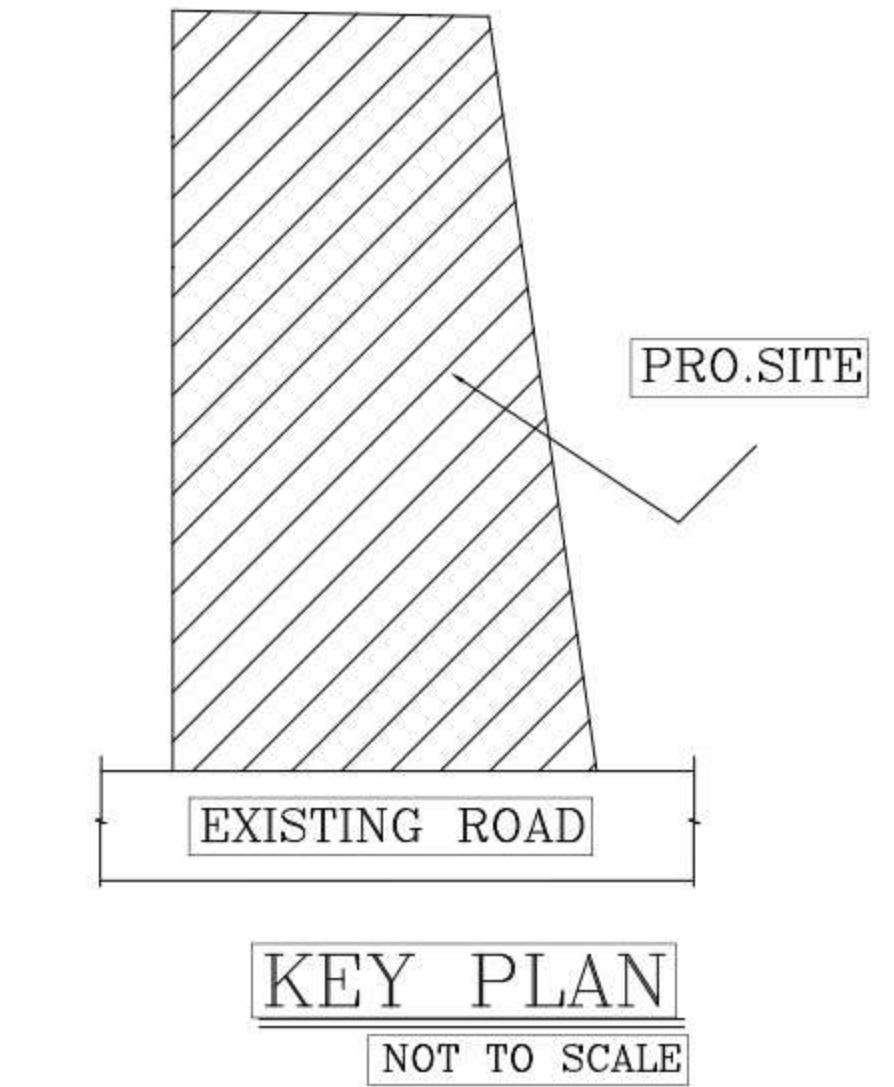
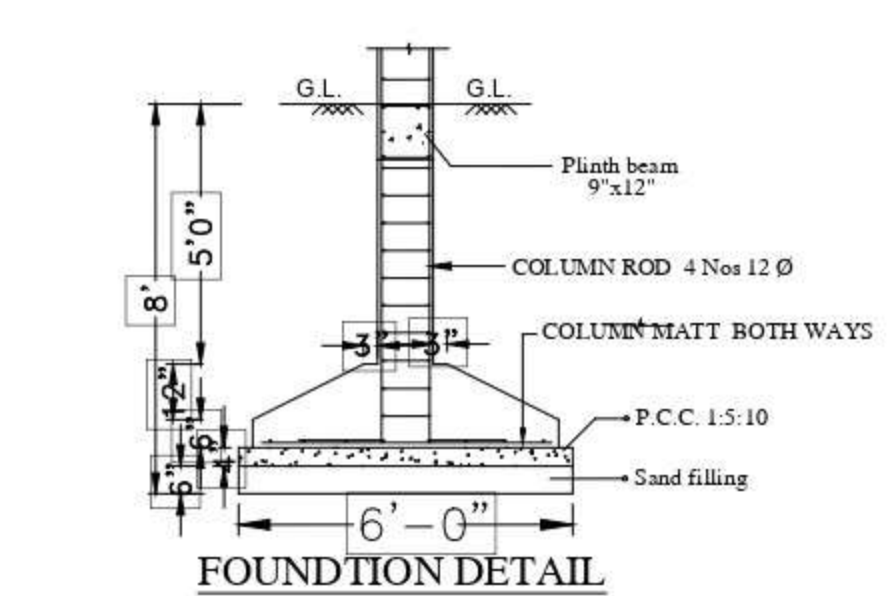

SCHEDULE OF JOINERY		COLOUR INDEX	
M,D	MAIN DOOR 6'0" X 7'0"	□	PLOT BOUNDARY
D1	DOOR 3'0" X 7'0"	□	EXIG. BUILDING
D2	DOOR 2'6" X 7'0"	□	PRO. BUILDING
W	WINDOW 6'0" X 4'0"	□	ROAD
W1	WINDOW 4'0" X 4'0"	□	
V	VENTILATOR 3'0" X 2'0"	□	

AREA STATEMENT			
	Sq.ft.	Sq.m	
PLOT AREA	61855.00	5749.00	
PRO. GROUND FLOOR AREA	2590.00	240.62	
PRO. FIRST FLOOR AREA	3150.00	292.64	
PRO. SECOND FLOOR AREA	3150.00	292.64	
TOTAL AREA	8890.00	826.00	
EXTG. GROUND FLOOR AREA	7150.00	664.50	
EXTG. FIRST FLOOR AREA	7150.00	664.50	
EXTG. SECOND FLOOR AREA	7150.00	664.50	
COVER AGE			
F.S.I	16%	0.49	
OPEN S P A C E AREA	52115.00	4843.40	

OWNER NAME:1.Mr.SUNDER RAMAN,
2.Mrs.SHOBHA SUNDER RAMAN

Sunder Raman
Shobha Sunder Raman
OWNER SIGNATURE

Er. M. NARENDARAN, B.E.,
Reg. No: 018 / LS / 2021 / 00002
Registered Engineer Grade - II (RE),
NAREN CONSTRUCTIONS
(Licensed Surveyor, Consulting Engineer)
No : 42, Pillayar Koil Street, Chengalpattu-603 002
Cell : 8056600443 / 8925292179

REGISTERED ENGINEER

NAREN CONSTRUCTIONS
Er.M.NARENDARAN
CONSULTING ENGINEER, LICENSED SURVEYOR
D.No.42,PILLAIYAR KOIL STREET
(ANUMANTHAPUTHERI) Cell:8056600443, 8925292179
CHENGALPATTU - 603 002.

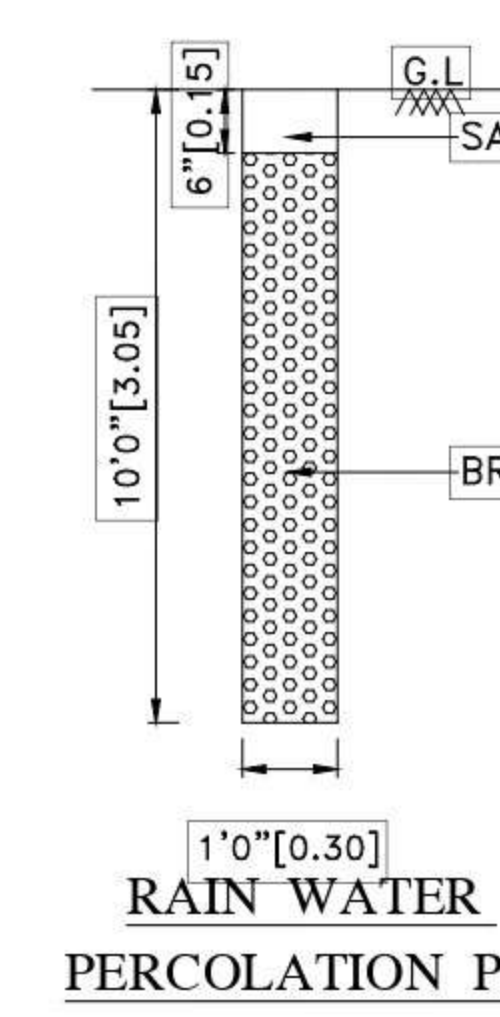
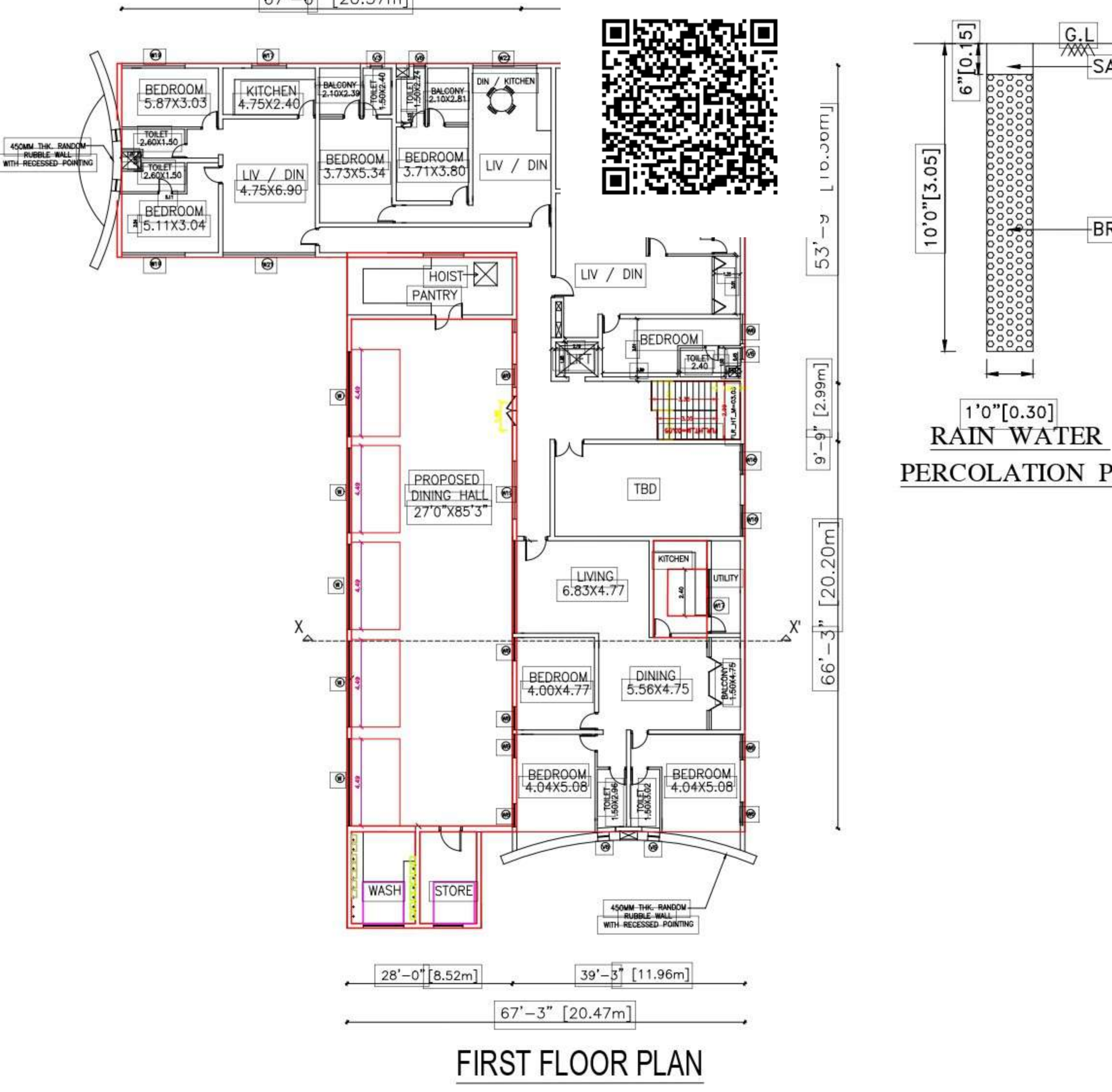
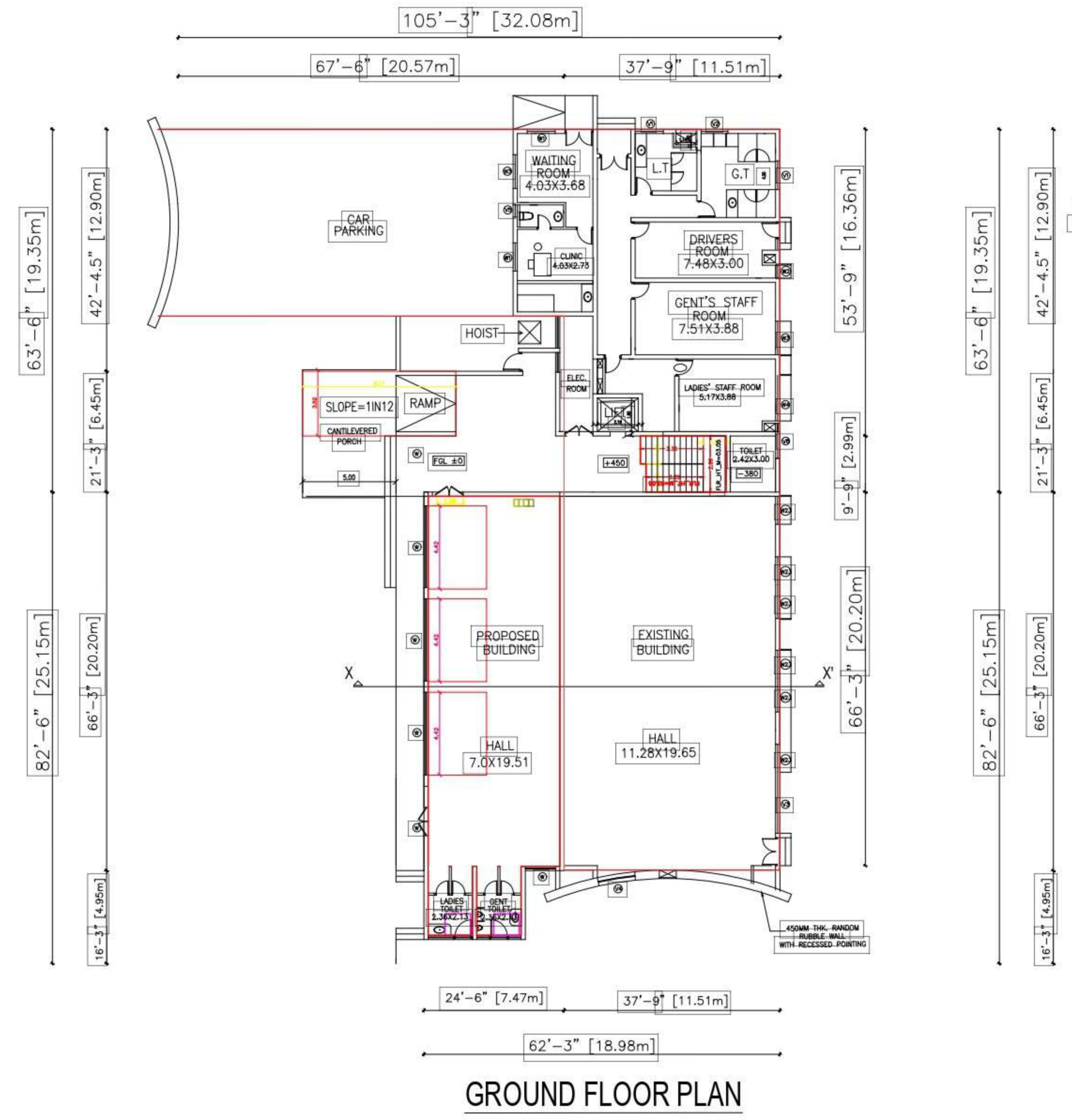

SCALE 1:100