

PLAN SHOWING THE PROPOSED GROUND FLOOR CONSTRUCTION OF SHOP COMMERCIAL BUILDING IN S.F.NO: 271/4B1B,

**MANAIVARI PATTA NO: 4575 AT KUNDAVELI (W) VILLAGE ,KUNDAVELI POST & PANCHAYAT,
UDAYARPALAYAM -Tk & ARIYALUR Dt.**

APPLICANT NAME :MR.SASIKUMAR s/o MR.ELAVARASAN.,

APPROVAL AUTHORITY:

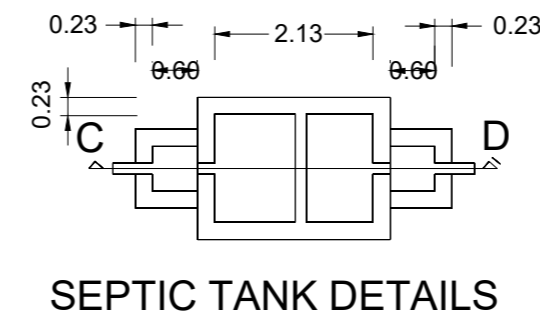
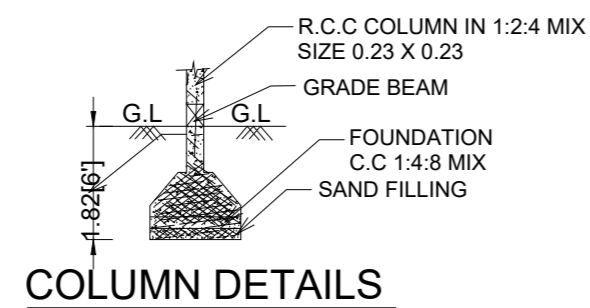
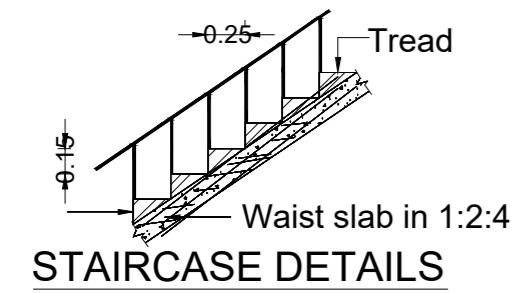
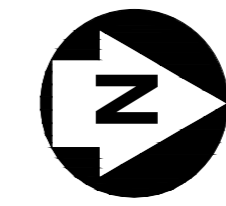
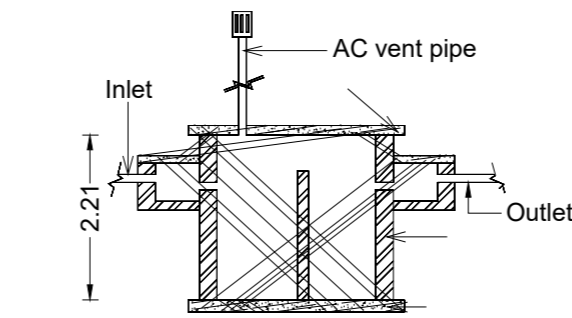
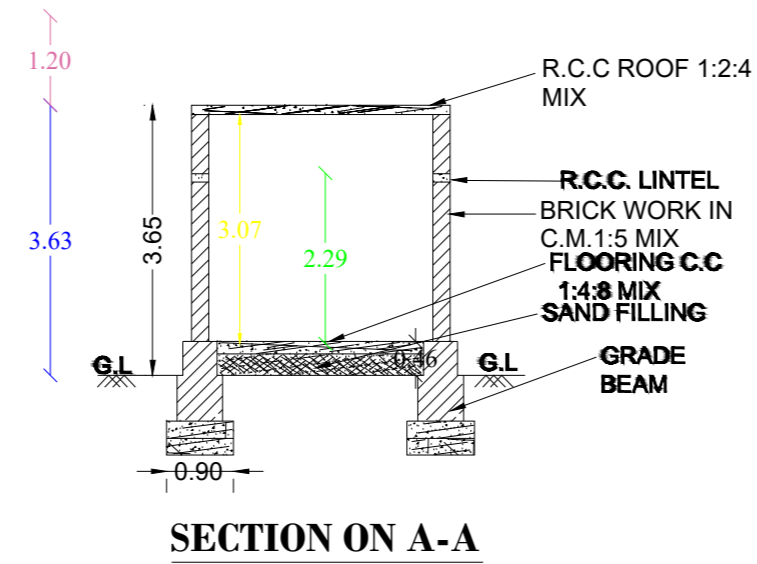
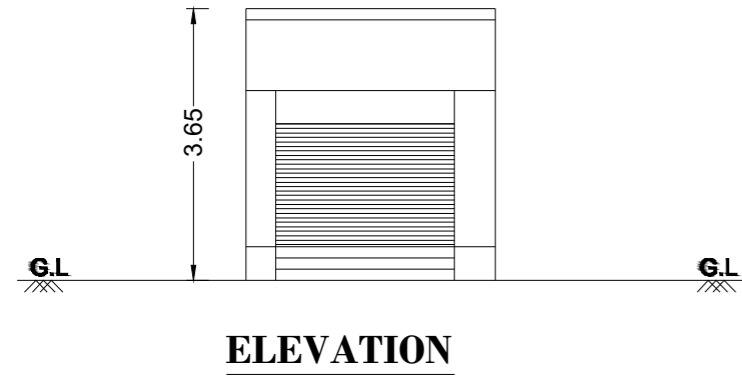

AREA DETAILS

AREA	IN SQ.FT	IN SQ. MT
PLOT AREA	10903.93	1013.00
GROUND FLOOR AREA	176.00	16.35
OPEN AREA	10727.93	996.65

JOINERIES DETAILS

DESCRIPTION IN ' FEET '	IN ' METRE '
R.S - ROLLING SHUTTER 7'0" X 7'0"	2.13 X 2.13
R.S 1 - ROLLING SHUTTER 1 4'0" X 7'0"	1.22 X 2.13

SCALE :- 1:100,
ALL DIMENSIONS ARE IN METRE

APPLICANT SIGNATURE :

APPLICANT NAME :
MR.SASIKUMAR s/o MR.ELAVARASAN.,

PROPOSED SITE BOUNDARY SHOWN IN
PROPOSED BUILDING SHOWN IN
ROAD SHOWN IN

ENGINEER:

