

PLAN OF PROPOSED CONSTRUCTION OF RCC ROOF GROUND FLOOR RESIDENTIAL BUILDING

IN R.S NO.251/1A1A, OLD R.S NO.251/1A1, PATTA NO.3005 AT KANGAVADANGANALLUR VILLAGE, MUTHUSERVAMADAM MADURA AND PANCHAYAT, UDAIYARPALAYAM TALUK,ARIYALUR DISTRICT, 612903.

OWNER: Mr. T. MICHAELRAJ. S/O THAVASEELAN.

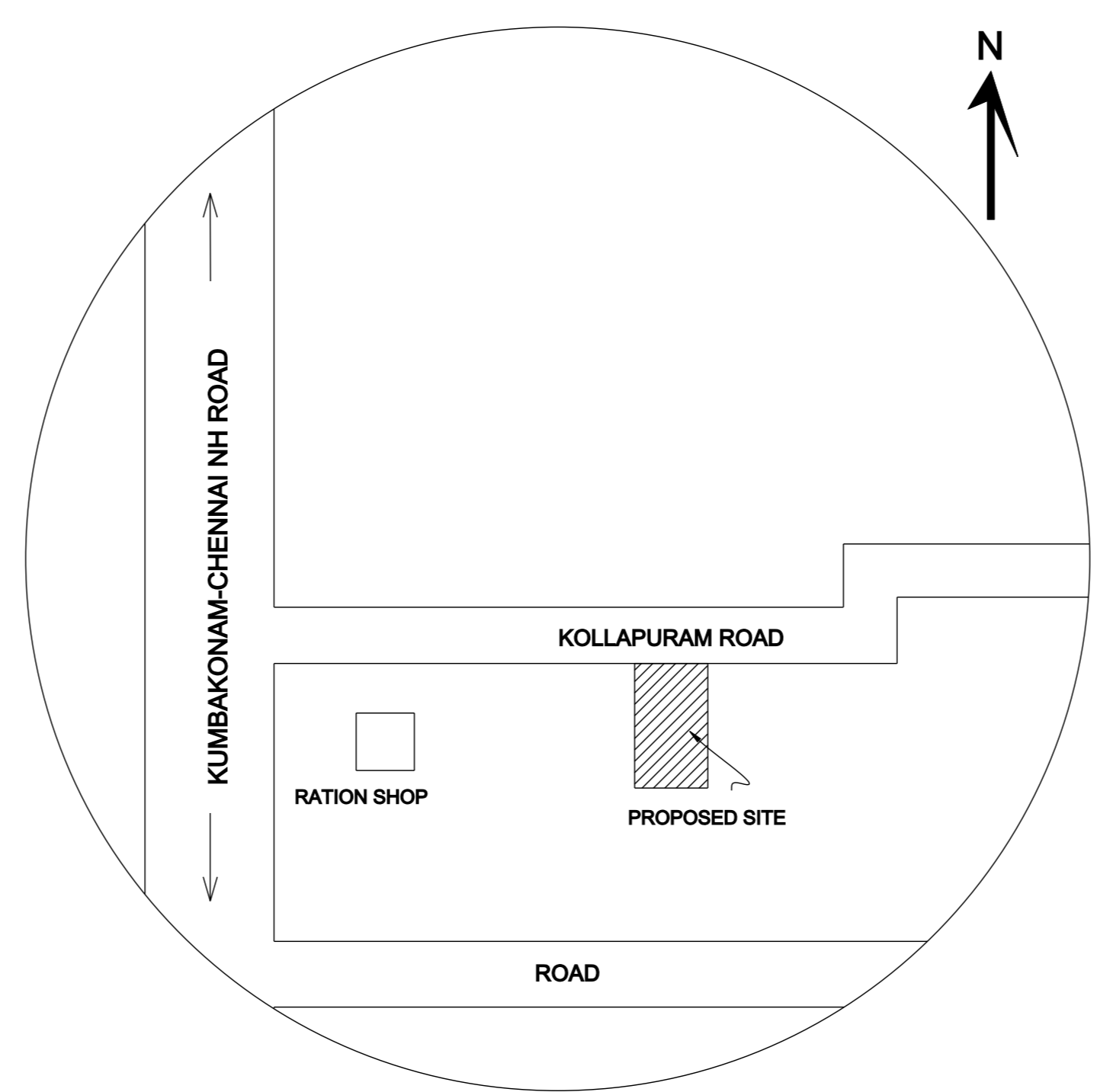
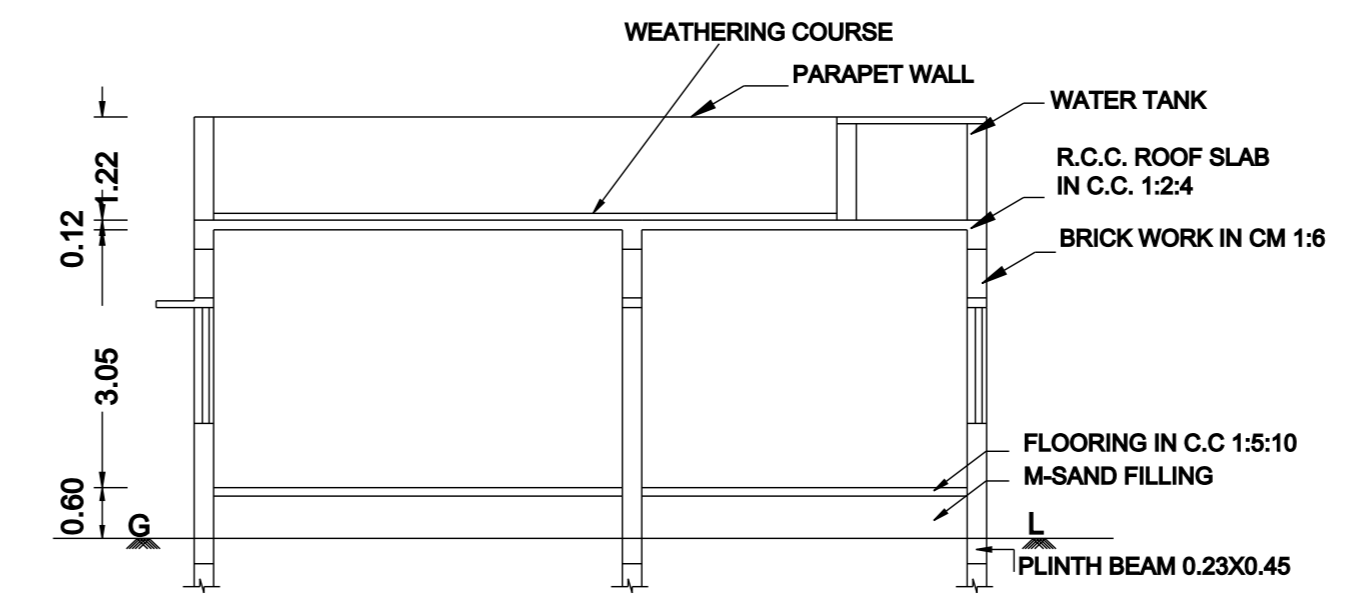
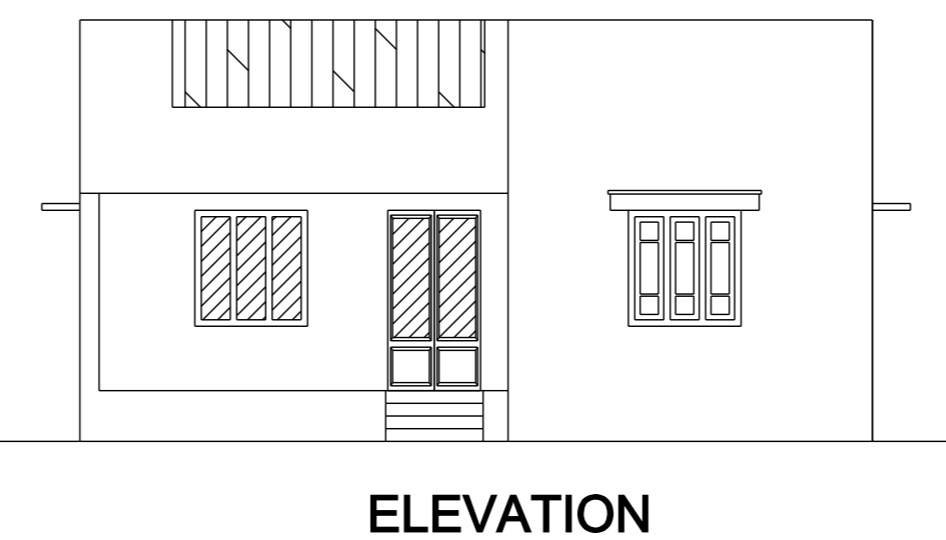
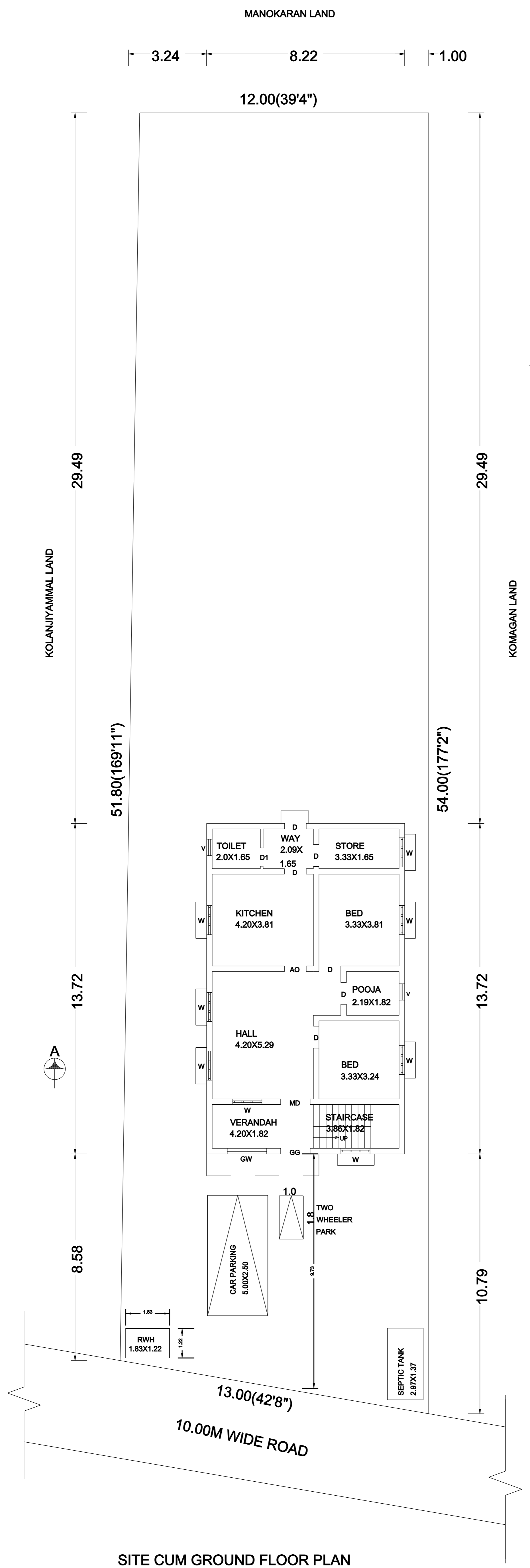

TOPO PLAN NOT TO SCALE  
KEY PLAN NOT TO SCALE

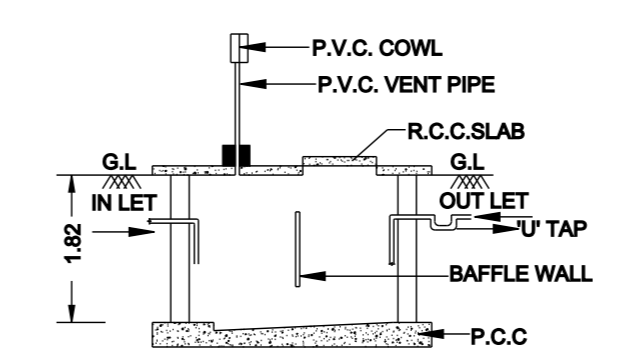

SEC. OF SEPTIC TANK "AA"

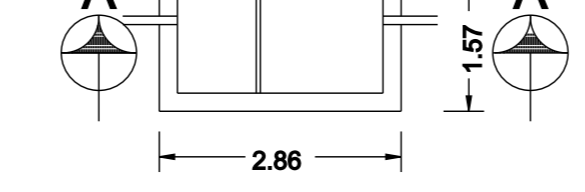

PLAN OF SEPTIC TANK

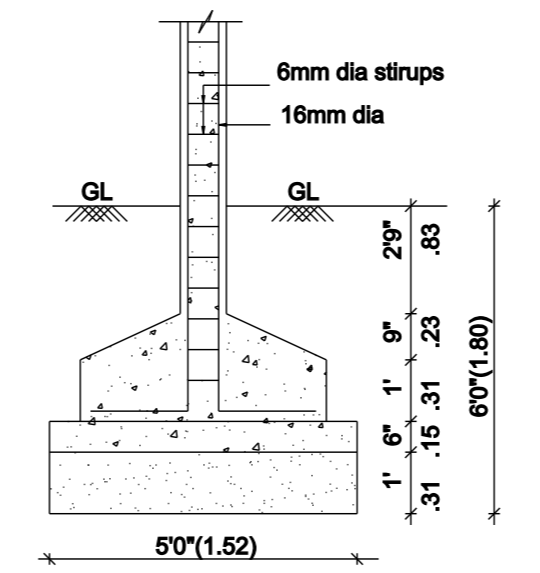

FOUNDATION DETAIL SCALE (1:50)

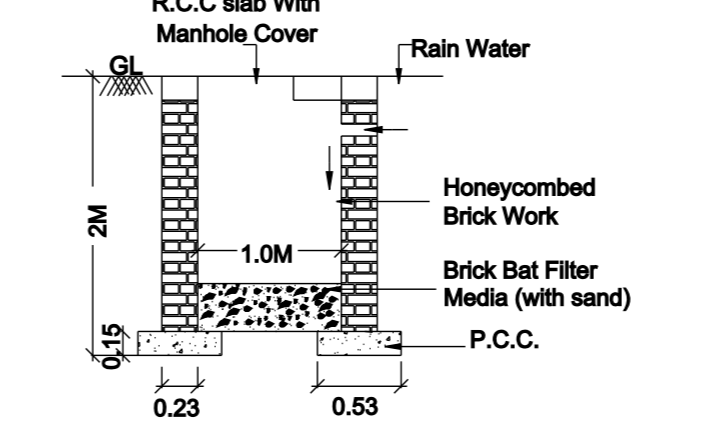

DETAILS OF RAIN WATER COLLECTION PIT SCALE:- 1"=40"

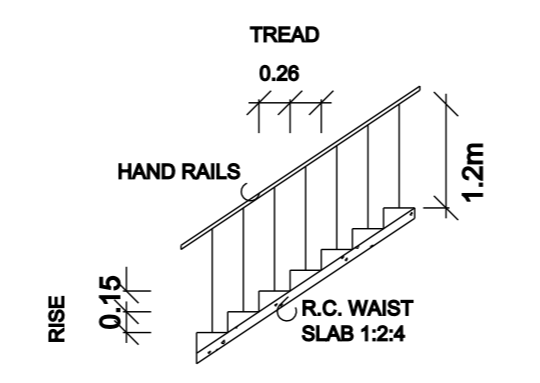

STAIRCASE DETAILS

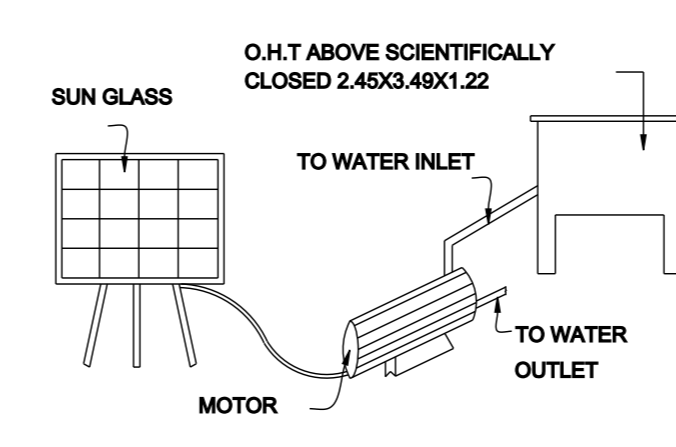

SOLAR WATER HEATING SYSTEM

SCALE - 1:100

ALL DIMENSIONS AREA IN METER		
AREA STATEMENT	AREA IN Sq.ft	AREA IN Sq.m
SITE EXTENT AS PER DOCUMENT	6996.60	650.00
SITE EXTENT AS PER FMB	7067.53	656.59
SITE EXTENT AS PER PATTA	6996.60	650.00
SITE EXTENT AS PER SITE	7067.53	656.59
PLINTH AREA-PROPOSED GROUND FLOOR	1213.96	112.78
TOTAL BUILT UP AREA	1213.96	112.78
CARPET AREA-PROPOSED GROUND FLOOR	1107.62	102.90
OPEN AREA	5782.64	537.22

FSI: 0.173      P.C: 17.35%

SCHEDULE OF JOINERIES

TYPE	DESCRIPTION	SIZE
MD	MAIN DOOR	1.22 X 2.13
D	DOOR	0.91 X 2.13
D1	DOOR	0.76 X 2.13
W	WINDOW	1.22 X 1.37
W1	WINDOW	1.22 X 0.90
V	VENTILATOR	0.90 X 0.60

COLOUR CODE :

BUILDING		STAIR DETAILS
ROAD		WIDTH - 0.91
BOUNDARY		TREAD - 0.27
		RISE - 0.15

OWNER / APPLICANT :  
*T. Michaelraj*  
(T.MICHAELRAJ)

REGISTERED ENGINEER  
*Er.A. Ganapathy*  
**Er.A.GANAPATHY, B.TECH, F.I.I.V, C.Engg.,**  
Govt. Registered Engineer (RE/Gr.III/005/2022),  
Chartered Engineer (M - 110749/15),  
Approved Valuer (CAT - I - F - 6977),  
4, Muthu Vinayagar Street, Periyar Nagar,  
Kattumannarkoil, Cuddalore District - 608 301.  
Mobile : 9443576912, 9976964704  
Mail : ganapathy.a9@gmail.com.

Er.A.GANAPATHY, B.TECH, F.I.I.V, C.Engg.,  
Govt. Registered Engineer (RE/Gr.III/005/2022),  
Chartered Engineer (M-110749/15),  
Approved Valuer (CAT-I-F-6977),  
4, Muthu Vinayagar Street, Periyar Nagar,  
KATTUMANNARKOIL, 9443576912 / 9976964704

