

**PLAN SHOWING THE PROPOSED CONSTRUCTION OF A RESIDENTIAL BUILDING AT  
S.No.72/10A1C, PATTA No.531, VILLAGE No.43, RUDHRAKOTTI VILLAGE,  
THIRUKAZHUKUNDRAM TALUK & TOWN, CHENGALPATTU DISTRICT.**

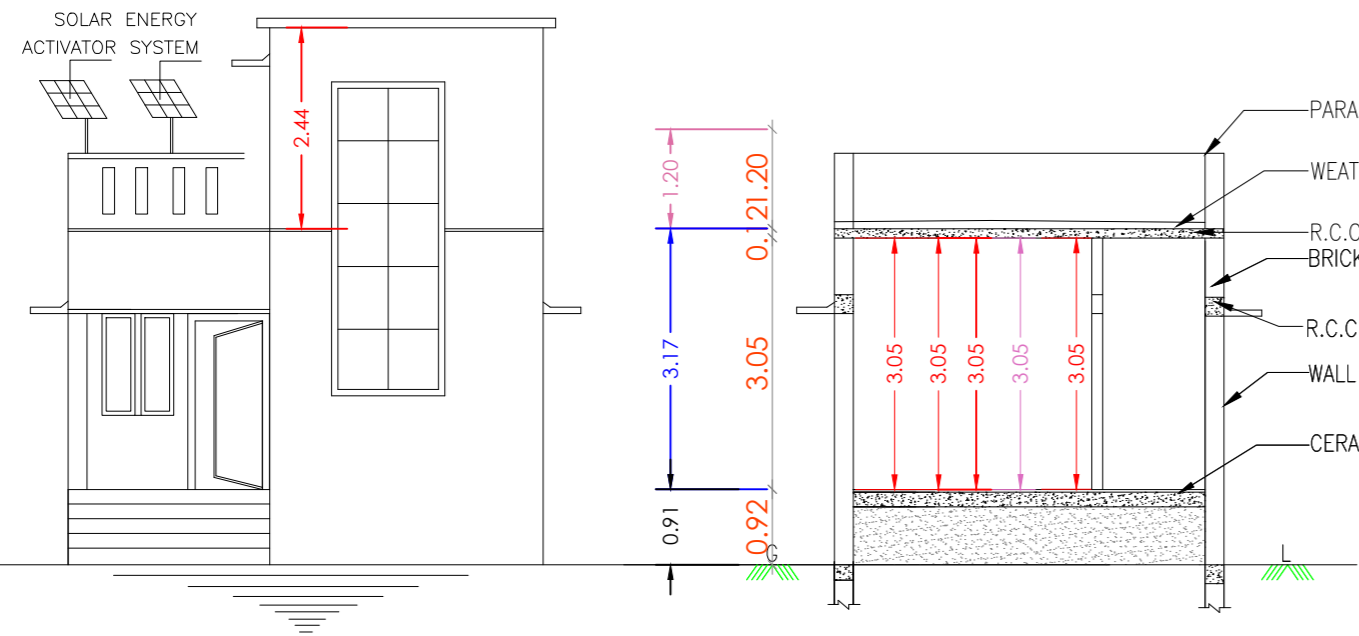

**FRONT ELEVATION**

**SECTION ON "AB"**

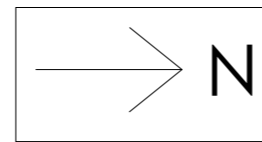
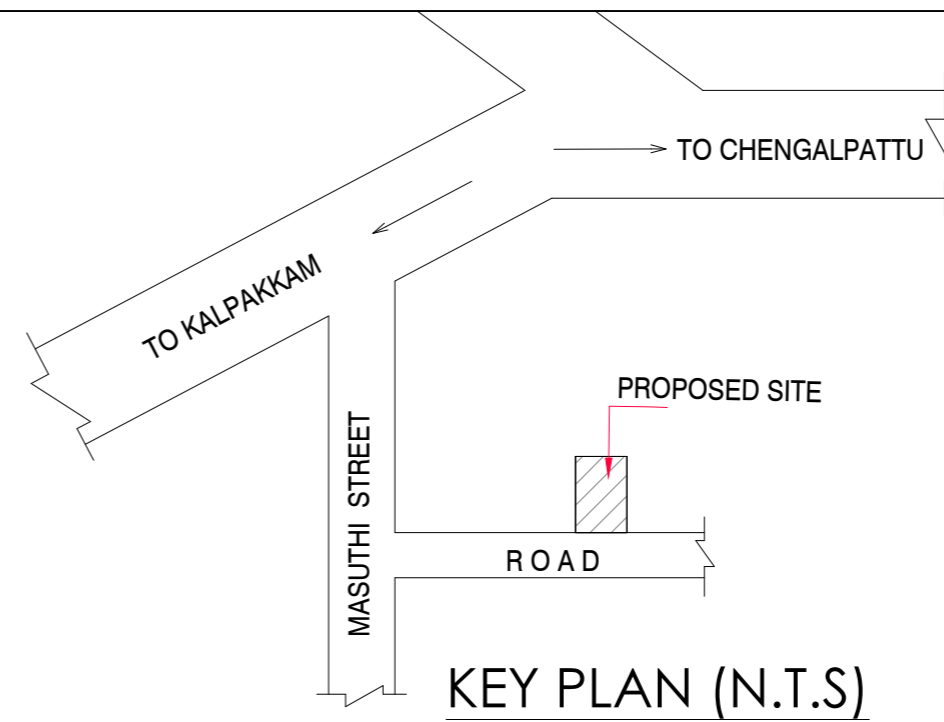
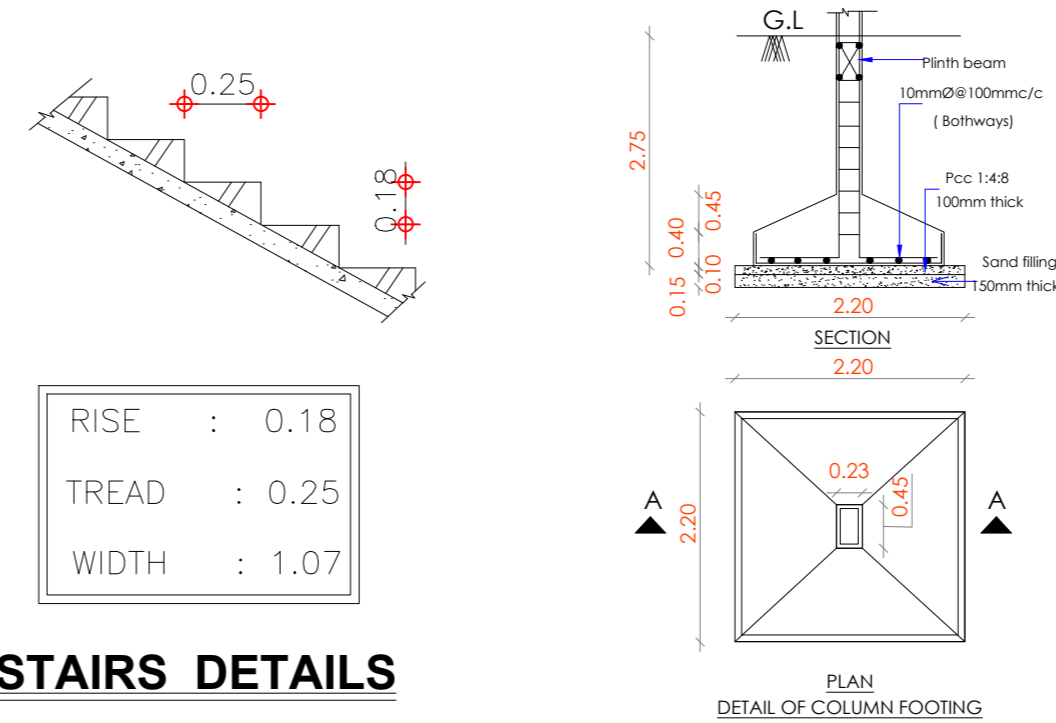

**STAIRS DETAILS**

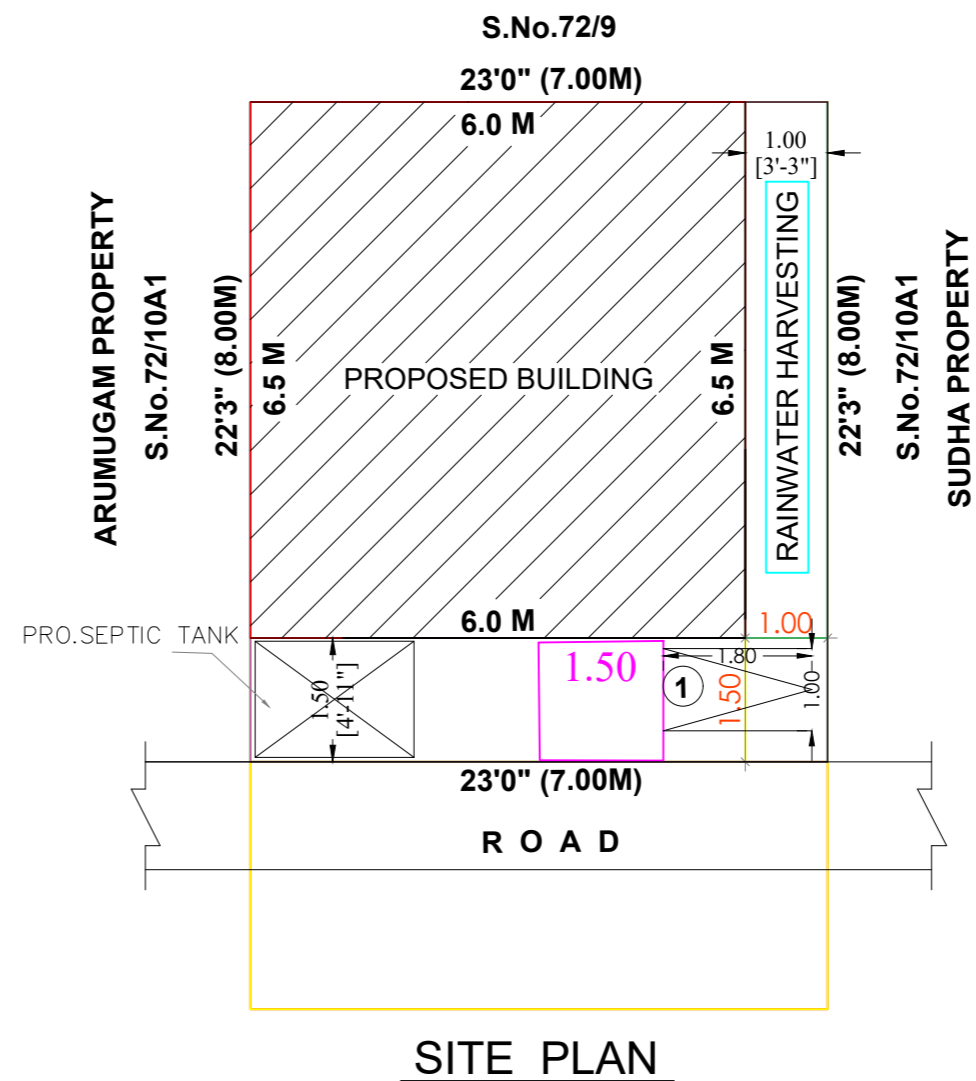
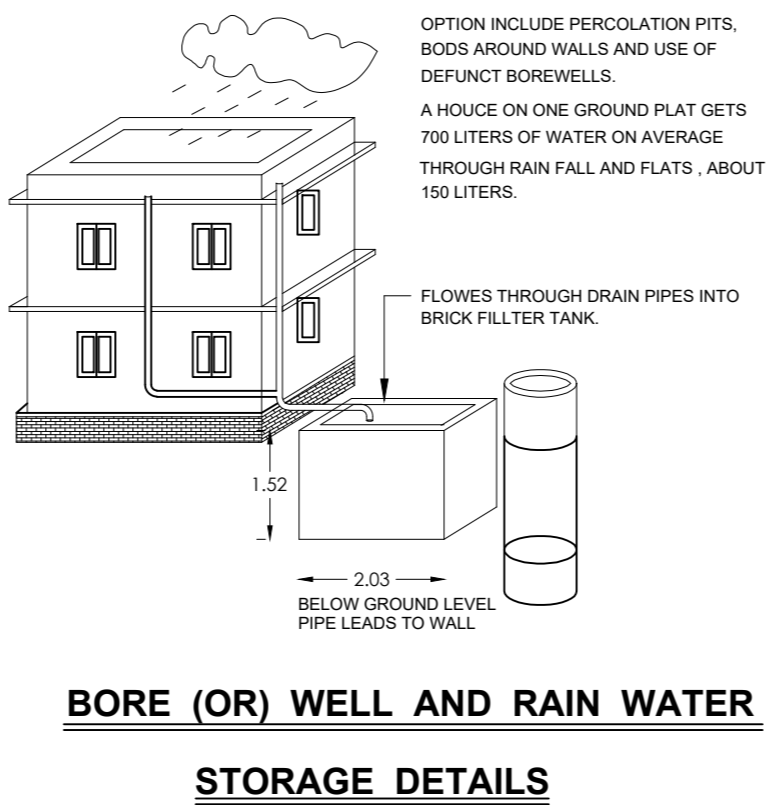
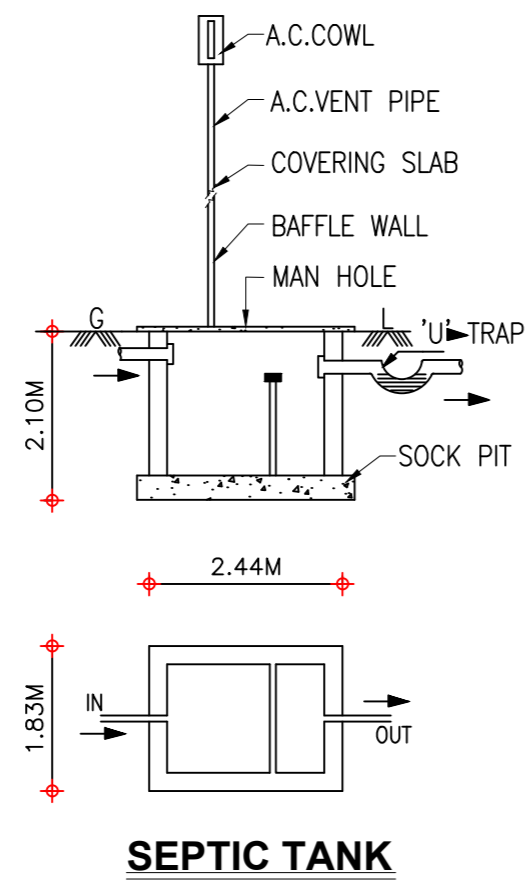
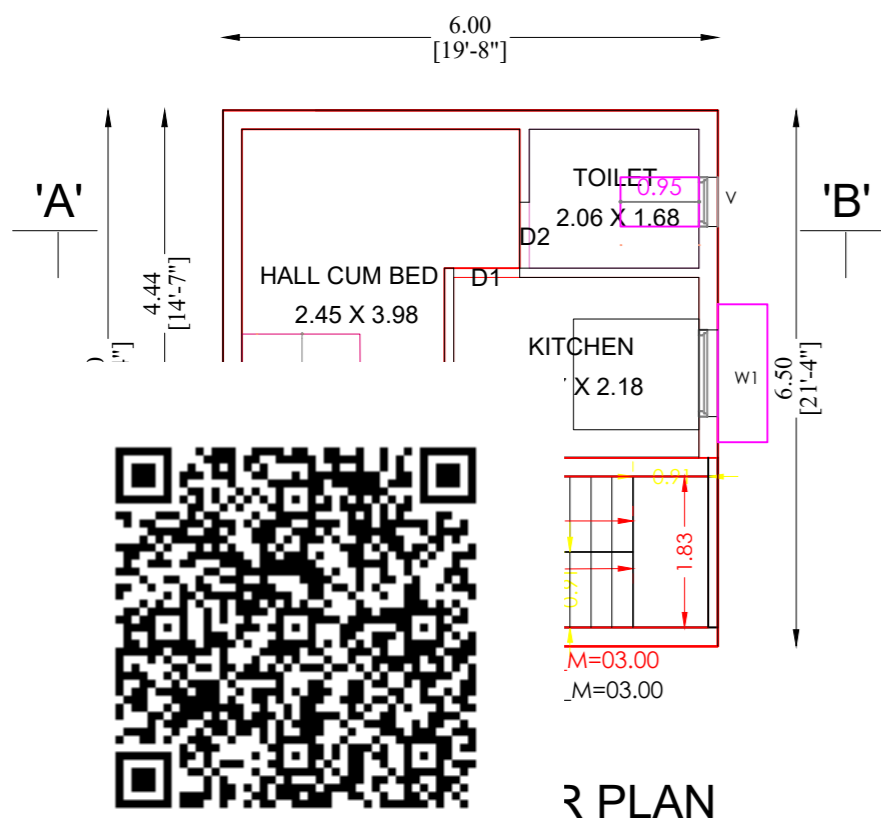
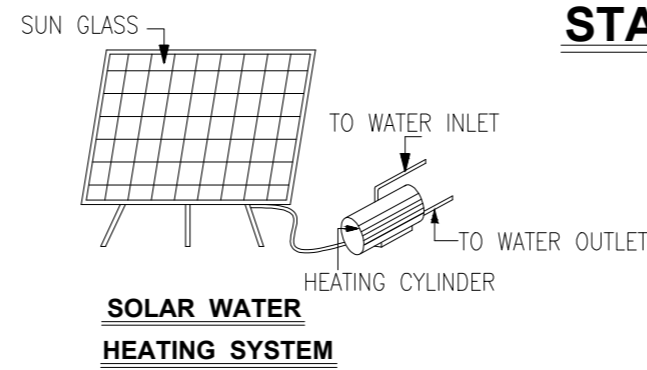

OFFICE USE

SCHEDULE OF JOINERY		COLOUR INDEX	
M.D. DOOR	1.00 X 2.10	PRO.BUILDING	<input type="checkbox"/>
D1 DOOR	0.90 X 2.10	PLOT BOUNDARY	<input type="checkbox"/>
D2 DOOR	0.75 X 2.10	R O A D	<input type="checkbox"/>
W WINDOW	1.37 X 1.22		
W1 WINDOW	0.90 X 1.22		
V VENTILATOR	0.90 X 0.60		
G.G. GRILL GATE	1.00 X 2.10		
R.S ROLLING SHUTTER	1.80 X 2.10		

AREA DETAILS	SQ.FT.	SQ.MT.
PLOT AREA (AS PER DOCUMENT)	603.00	56.00
PLOT AREA (AS PER PATTA)	603.00	56.00
SUPER IMPOSED AREA	603.00	56.00

AREA DETAILS	SQ.FT.	SQ.MT.
PLOT AREA	603.00	56.00
PRO.G.F BUILDING AREA	419.81	39.00
C O V E R A G E	69.7%	
OPEN S P A C E AREA	183.19	17.00

**OWNER : Mrs.G.UMAPATHMINI**

*(Handwritten Signature)*

OWNER'S SIGNATURE

**M. DOSS, D.C.E.,**  
Registered Engineer Grade-II (RE)  
Reg. No : 018 / LS / 2023 / 00001  
**PARVATHY CONSTRUCTION**  
No: 7/6, CN Mahadevan Street,  
Chengalpattu - 603 001  
Cell : 9962 33 9625

LICENSED SURVEYOR / REGISTERED ENGINEER

PARVATHY CONSTRUCTION, CHENGALPATTU. CELL- 99623 39625.